



DELPHI

Be Creative!

EZ-Pro Deluxe™ 15-6 Kiln

Delphi has teamed up with Jen-Ken Kilns and Orton to produce the most user friendly, versatile kiln for glass and ceramic artists ever.

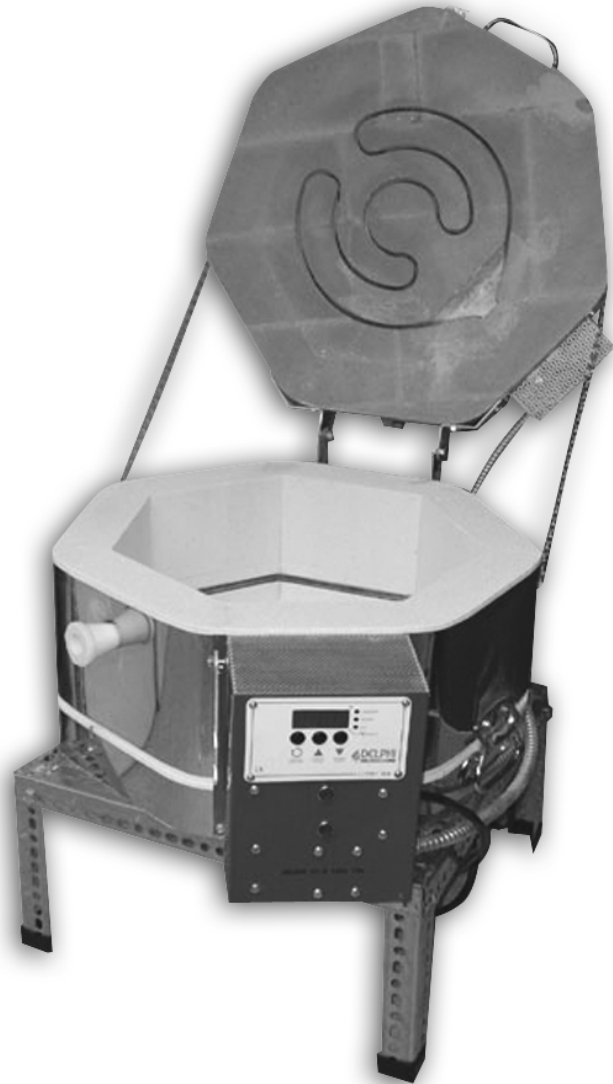

www.DelphiGlass.com • 800-248-2048
3380 E. Jolly Road • Lansing, MI 48910

This manual contains instructions on the operation of the kiln and Delphi EZ-PRO DELUXE™ controller as well as a discussion of general fusing and ceramic firing procedures. It is not intended to replace a fusing/ceramics class or comprehensive fusing instructional media.

Table of Contents

Safety First.....	5
About Your Kiln.....	6
Introduction	6
Kiln Accessories.....	7
Kiln Specifications	9
Choosing a Location for Your Kiln.....	10
Setting up Your Kiln	11
Quick Start Guide <i>or</i>	
Enough Reading – I want to melt something!.....	12
EZ-Pro Deluxe Controller.....	13
Audible Alarm.....	14
Temperature Display Preference.....	14
Temperature measurement.....	14
Temperature Control	14
Firing Program Terminology.....	14
Program Modes.....	16
Changing Program Modes.....	16
Selecting the Firing Schedule or Programs	16
90 COE program mode	17
96 COE program mode	18
Bead program mode.....	19
Metal Clay program mode	20
Ceramic program mode	21
User program mode.....	23
Other program Notes.....	24
Delay Start Option	25
Thermocouple offset option	25
Program Review	25
Options Menu.....	26
Skip Step	26
Add Hold Time.....	26
Changing Heating/Cooling Temperatures	26
Threshold alarm	27
Flow diagram for options menu	27
Power fail recovery.....	28
Status Display Codes.....	28
Alarm Display Codes.....	29
Wiring Diagram.....	31
Beginner Instructions.....	32
Fused Glass Project.....	32
Working with tested compatible glass.....	32

How to prepare your glass project.....	32
Firing your glass project	32
Firing Process	33
Firing Stages	34
Firing 90 COE Glass for Beginners.....	36
Firing 96 COE Glass for Beginners	38
Batch Annealing Glass Beads.....	40
Firing Your Metal Clay Projects	42
Firing Ceramic Program	44
Intermediate Mode	46
Keeping a log	46
Changing pre-programmed firing programs.....	46
Professional Mode	47
Firing Programs.....	49-58
Controller Warranty.....	59

SAFETY FIRST

Read and understand all operating instructions before operating your kiln.

SAFETY PRECAUTIONS: Kilns are as safe as any other electrical appliance when used under normal and proper operating conditions. All safety precautions throughout this manual should be observed.

- Use common sense while installing and using this kiln.
- Do not install kiln closer than 12" from any surface, or closer than 18" from a combustible surface. Remove all potentially combustible materials from the kiln area
- Make sure all electrical specifications are followed. Use correct voltage, wire size and circuit breaker. Make sure all connections are tight. Avoid using aluminum wire. Always use the proper grounded receptacle. A qualified electrician or service person should be used for all electrical service or repairs.
- Install in covered, walled in, well-ventilated area. Do Not allow your kiln to get wet. Fumes from the ware should be vented to the outside. Never use your kiln outside! Avoid moisture.
- Always keep children and unsupervised personnel away. Surface will get hot and a burn could result.
- Fire clay, glaze, overglaze, and glass only to the manufacturers recommended firing temperature. Improper fire temperatures could result in damage to your kiln. Do not operate kiln over the maximum temperature rating of 2000°F.
- Replace any worn or defective parts with ONLY genuine Jen-Ken Kiln replacement parts.
- Unplug the kiln before servicing or vacuuming.
- Do not drop or slam the lid shut.
- Let the kiln cool to room temperature before opening the lid.
- NOTE: If you are in doubt about anything, call Delphi Glass 800.248.2048 or Jen-Ken Kilns during regular business hours at 800.329.KILN.

ABOUT YOUR KILN

Introduction

The Delphi EZ- Pro Deluxe™ Kiln 15-6 is a professional quality Jen-Ken kiln.

The controller has been designed and programmed to Delphi specifications by Orton Ceramics.

Elements

Elements are the coils of wire that produce heat inside the kiln. They are made from a high quality, high-temperature wire. During the firing, they become very soft and when cool become brittle. Life expectancy of the elements will depend on the number of firings and the firing temperatures. At lower temperatures, the elements will last longer than firing at higher temperatures. Care should be taken to make sure that no foreign matter (such as glazes, clay or kiln wash) come in contact with the elements. This will greatly reduce their life expectancy. Regular vacuuming of the kiln lid, bottom and the element grooves is recommended.



In a digital kiln, the coils as a group turn on and off during firing. You will hear the clicking of the relays. It will click more if a slow rate of rise in temperature is used and less if the kiln is told to fire quickly. Your EZ-PRO Deluxe kiln has separate relays for the top and side elements to increase the life of the relays.

The EZ-Pro Deluxe™ kiln has coils in the lid and side walls. There is a switch on the side to switch from the glass mode (1700 degrees F Max) to the ceramic mode (2000 degrees F Max).

Glass Mode: Up to 1700 F for glass fusing and slumping: Both lid and side coils are used for glass. These coils are designed to put an even blast of heat down onto the glass. The lid coils do most of the work in the kiln and glow the most. Side coils are supplemental heat and help bring the kiln to temperature. It takes the side and the lid coils to bring the kiln to fusing temperatures.

Ceramic Mode: Up to 2000F or Cone 02 for ceramics. In the ceramic/cone mode only the side coils turn on, side elements only allow the kiln to go to higher temperatures.

DO NOT FIRE OVER 1700F DEGREES IN THE GLASS MODE AS THE LID COIL WILL BURN OUT.

SAFETY FIRST: In a digital kiln, if a relay fails, the section that the relay controls might not heat up, or could stay on continuously. If this happens, turn off the kiln at the breaker and unplug. At this point, you will need to replace the relay. Call Jen-Ken Kiln Company for assistance.

Elements Cont.

The EZ-Pro Deluxe Kiln has multiple relays so that if one relay fails the kiln cannot heat too high in temperature.

Kiln Brick

All Jen-Ken kilns are made of hand selected 2400°F refractory brick. The brick is strong as a whole and has a very long life. The brick can chip easily and care should be taken to avoid bumps while loading and unloading shelves. Frequently vacuum the brick lid, the grooves that the elements are in and the bottom of the kiln. This will remove the dust, sand and loose kiln wash from the kiln.



Kiln Jacket

Your kiln is encased in a stainless steel jacket and is also equipped with handles for easy moving. Due to the high temperatures, discoloration may appear on the stainless jacket. A good metal polish will remove this discoloration.

Accessories

Shelves: Shelves help you make the most of the inside for your kiln. Shelves are sized a few inches smaller than the inside diameter of the kiln so that they can be placed in and out of the kiln more easily. They are made of refractory material so that they should be handled carefully. Should a crack appear in a shelf, break the shelf along the crack and use it as two separate pieces. A good coat of kiln wash should ALWAYS be maintained on top of the shelves. Store shelves upright on edge, leaning on a sturdy structure, not flat on their sides. Shelves stacked flat can put too much pressure on the bottom shelf and cause it to stress and crack. Store shelves that are not in the kiln on edge.

Posts: Posts are also made from refractory material and should be handled carefully. Post sizes range in heights from ½" to 14". They are used to support the shelves in your kiln at different levels depending upon the height of the pieces you are firing. Usually, three posts allow you to level the shelf more easily (although some fusers/ceramists prefer four).

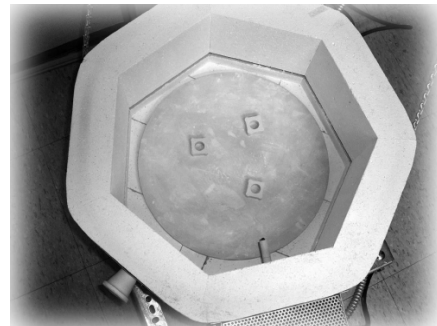

RECOMMENDED KILN ACCESSORIES



Glass Kiln Wash is a mixture of very fine minerals that will not fuse or melt together at high temperatures and act as a barrier between the kiln shelf or mold and glass. It is used to prevent glass from sticking to the firebrick bottom of the kiln and the kiln shelves.

Kiln wash is a powder that's mixed with water to form a wash that's brushed onto kiln shelves. When mixing, follow manufacturer instructions for powder and water ratio and use care and do not breathe in the powder. (A DUST MASK IS RECOMMENDED) Kiln wash has an unlimited shelf life in dry powder form.



The **Haik Brush** is a very absorbent natural bristle brush used to apply kiln wash onto the kiln shelf in a very smooth, thin layer.

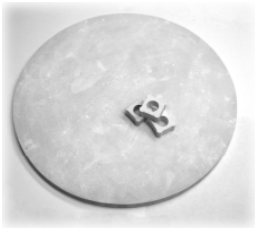

Kiln shelves and posts are made of a high-fired clay, like mullite, that has been fired to temperatures that are higher than what can be fired in your kiln. When working with glass in a kiln, you should always fire your glass on either a kiln shelf or a mold. It is necessary to coat the surface and edges of the kiln shelf with kiln wash to prevent glass from sticking to it while firing.



Always wear **Safety Glasses** whenever you look into a hot kiln to protect your eyes from infrared and ultraviolet light.



Hot gloves and / or Lid Lifter: An operating kiln is very hot. These items can help preclude burns.

KILN SPECIFICATIONS

To operate the kiln safely and efficiently, your kiln needs the proper electrical outlet with the correct electrical capacity and voltage. The chart below will assist you in the selection of the proper wire and breaker size for your Jen-Ken Kiln. A licensed electrician or the local power company should determine if you have the proper voltage and wiring.

Model	Width	Depth	CU/FT	Max Temp	Volts	Amps	Watts	Receptacle	Ship Weight
Orton Auto Fire 3 Button	Uses a 3 Button Controller with One 8 Segment Program – For Simple Programs								
AF4P 15/6	15"	6.5"	.66	2000	120	15	1800	5-15R	85

CHOOSING A LOCATION FOR YOUR KILN

The proper location is as important as choosing the right kiln. Below are some safety guidelines.

- Please review the safety considerations listed on page 5 when selecting a location for your kiln.
- Your kiln should be located in a covered, dry, fireproof and well ventilated area, but NEVER in a small enclosed area such as a closet, cabinet or very small room. Otherwise, the room temperature will increase past a reasonable level quickly. In a larger room, the exterior of the kiln will stay cooler than in a very small room.
- Your kiln should be on a cement or fireproof surface and positioned a minimum of 12" from any surface. The best and safest place for your kiln is on a cement floor. If not, some type of adequate fireproof material should be used beneath the kiln to prevent a possible fire hazard or prevent discoloration of the floor.
- Concrete blocks 8" x 8" x 16", with holes up, may be used to raise the kiln to a higher level. Solid bricks transfer heat through to the floor and should not be used.
- Air circulation and ventilation are needed to remove heat and vapors that may be released from the firing. In a larger room, the exterior of the kiln will stay cooler than in a very small room. If ventilation is a problem, call to see if an Orton Vent System or a hood system is applicable.
- Proper electrical service must be available. Refer to the section on Electrical Specifications. Select a grounded, three-pronged receptacle that is as close as possible to either your fuse or breaker box. DO NOT use extension cords.
- Remove all flammable or combustible materials such as gasoline, paper, paints, plastics, etc. from the surrounding area.
- Since the exterior of the kiln gets very hot, place the kiln out of the way of children, traffic, and work areas.
- Do not let the power cord come in contact with the kiln. The kiln may need to be rotated a little for the cord not to touch the kiln.
- Never install a kiln outside and avoid undue moisture.

SETTING UP YOUR KILN

- Assemble the kiln stand and place it on the floor in your work space.
- Remove all packaging from the kiln and place it on the stand. Do not plug it in yet.
- Make sure that your kiln sits completely level. It may be necessary to use a level to determine
- Open the lid of the kiln and inspect the interior looking for anything unusual like broken brick.
- Carefully inspect both the side and top heating element coils to make sure that they are seated back in the grooves. Try to avoid touching the coils with your fingers, as oil from your skin may cause premature element failure.
- Vacuum out the interior of your kiln and along the grooves in the lid to remove any debris that may come loose when you close the lid or during firing.
- Carefully brush kiln wash on the floor of your kiln. This is preventative maintenance in case glass ends up the floor of the kiln. Do not brush kiln wash on either the sides or lid of the kiln. Do not get kiln wash on any heating elements.
- Position the ½" kiln posts on the bottom of the kiln spaced out evenly to support the kiln shelf.
- Your kiln has been pre-fired at the Jen-Ken factory, and should not require a pre-firing prior to its first use. However, should you chose to do one anyway, you may select any of the built-in programs. One of the METAL CLAY firing programs would offer the fastest firing schedule. (Such as **P-FS**, page 39, 40)
- You're now almost ready to plug in the kiln and fire it for the first time. Before we go there, however, It's important for you to get acquainted with your EZ-PRO Deluxe controller.



Make sure your kiln sits level.



Vacuum any loose debris

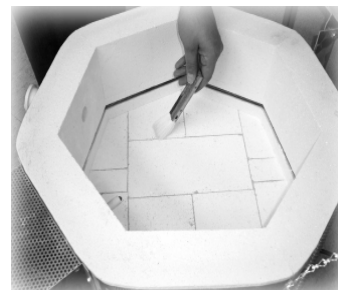

Brush kiln wash on the floor.

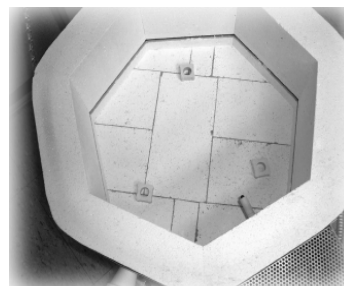

Position posts on the bottom.

Enough of this reading stuff – I want to melt something!

For those of you who can't wait, here is a brief guide to get you up and running. It is strongly recommended that you do take time to look over the controller instructions as soon as possible.

Quick Start Guide:

Plug the Kiln in to an appropriate outlet and turn it on using the toggle switch on the side of the control box.

The display will first indicate **88.88** for about five seconds, then indicates the firing configuration that the controller is in (**-90-**, **-96-**, **bEAd**, **CLA**, **COnE** or **USR**) for about 10 seconds. The display then alternates between the internal kiln temperature and **IdLE**.

If you need to change the firing mode;

- Press and hold the (increase) button until the LED display shows **CFG**.
- Press the (Program) button to display the current firing configuration.
- Press the (Increase) button to move to the correct firing configuration,
- (**-90-**, **-96-**, **bEAd**, **CLA**, **COnE** or **USR**)
- Press the (Program) button to select the desired configuration – The display will return to the **IdLE** / Temp indication.

To select the firing program;

- Press the (Program) button to display the current firing program.
- Press the (Increase) button to scroll to the desired firing program for your project.
- Press the (Decrease) button to select the desired program. The small LED beside "Review" will light, and the LED display will show **rA 1**.
- You may either manually review the firing program, or simply do nothing and the controller will automatically do a rapid step through for you.
- Once the review has been completed, the display will show **Strt**.
- Press the (Program) button and the kiln will display **-On-** and begin the firing program.
- If you need to stop the program, press the (Program) button again, the kiln will shut down, and the display will show **Stop**.
- Once the kiln has completed a firing program, it will shut down and display **CPLt**, alternating with the kiln temperature and total program time.

DON'T BE TEMPTED – DO NOT open the kiln until the display indicates that the kiln has reached room temperature!

Delphi EZ-Pro Deluxe Controller



This button is for selecting a firing program and advancing through the programming steps. After programming is complete, use this button to Start and Stop the firing.



This button is used to change the firing program during programming and to change the display values for specific program settings. During a firing, use this button for special firing options (including Skip Step).



This button is used to change the display values for specific program settings. It is also used to activate the Program Review feature.



When using the Increase and Decrease buttons to change number settings, the values will change more rapidly if the button is held in.

Status Indicator Lights

3 lights are located to the right of the display.

- Ⓞ Program lit during controller programming
- Ⓞ Review lit during Program Review.
- Ⓞ Run lit (blinks) during an active firing.

Audible Alarm

The controller is equipped with a small buzzer that will sound during button presses and at the successful completion of a firing for. The alarm will also sound to notify you of diagnostic alarms that may occur during a firing. To silence an active buzzer, Press any button.

Temperature display preference

All temperature displays on the controller can be viewed as °F (Fahrenheit) or °C (Celsius). The temperature display preference is set by positioning a small circuit board jumper on the back side of the controller that is labeled C/F. The C/F jumper has 2 pin positions, when installed on the 2 corresponding circuit board pins the controller will display all temperatures as °F(Fahrenheit). When no jumper is installed on the 2 circuit board pins the controller will display all temperatures as °C (Celsius). To determine if your controller is set for °F or °C without viewing the jumper position, the small decimal point light in the bottom right-hand corner of the display panel indicates °F or °C. If this decimal point light is lit, the controller is set for °C.

The C/F jumper position is shown on the wiring diagram included in this manual on page 31.

Temperature Measurement

The controller monitors and controls temperature from a single Type K thermocouple sensor. The thermocouple probes extend into the firing chamber to measure the temperature. Use caution to avoid damage to the system thermocouple. If the probe is damaged, the controller may not function properly.

Temperature Control

The controller heats the firing chamber by turning relays on and off at the appropriate rate to maintain the program schedule. It is normal to hear the clicking noises associated with turning relays on and off throughout the firing.

Firing Program Terminology

As we begin our discussion on programming your kiln, it may be handy to first discuss basic fusing terminology and fusing techniques.

All modern electronic kiln controllers require three pieces of information for each heating or cooling step (commonly called a "segment") of a firing schedule. These variables are:

- Heating or cooling rate (speed, commonly referred to as Ramp Rate)
- Heating or cooling temperature (Target, or Set Point Temperature)
- Time Spent at a specific heating or cooling temperature (Hold or Soak Time)

The following graphical representation of a "typical" firing schedule may help you visualize exactly what your kiln does. A complete firing schedule can be multiple heating and/or cooling steps or segments. However, for many applications a single step is all that is required. The maximum number of program segments in the EZ-Pro Deluxe controller is limited to 8.

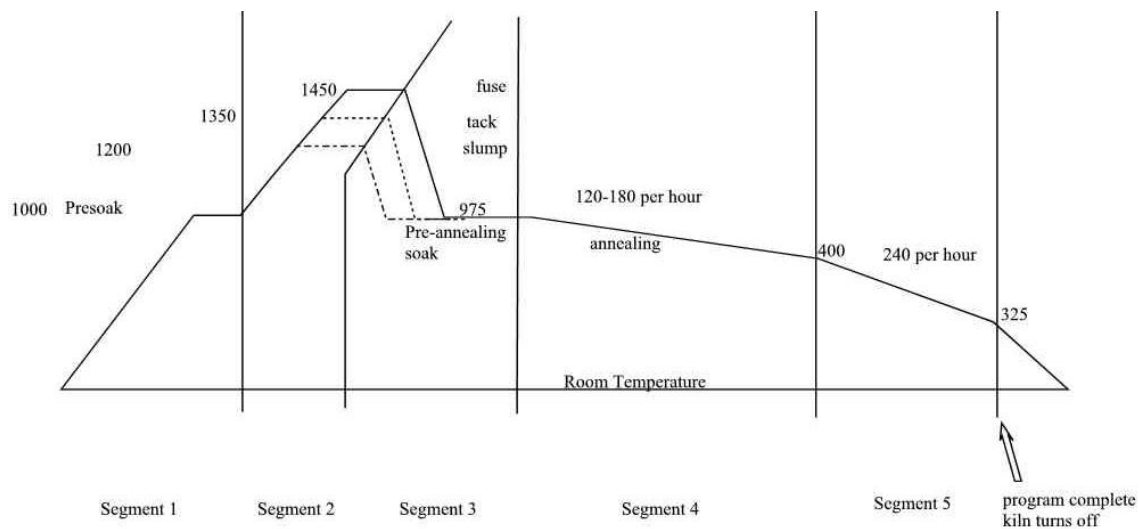

Ramp Rate

Each step of a firing program must have a programmed Rate of temperature increase or decrease. These rate values are selected as Degrees per Hour. During the programming the display prompt for Rate settings are **rA** followed by the step number like **rA1**, **rA2**, **rA3**, etc.... This may be either a positive number (for heating), or a negative number for cooling. To heat or cool as fast as possible, an alternative setting is available at the beginning or end of the temperature range. This setting appears as **FULL** on the controller display. If zero is set for any rate, this tells the controller that there are no more steps to your firing schedule, and ends your program. This feature can also be used to erase an entire firing program by setting the first **rA1** value to zero. The ramp rates built in to the controller were selected to give optimum performance for most projects. You may need to modify this part of the firing schedule if you have a special project.

Target or Set Point Temperature

After the ramp rate has been set, the target hold temperature is then selected. Once again, the built in temperatures are suitable for a typical project, by may need to be modified for certain special projects.

Hold / Soak Time

Hold or soak times are important parts of the firing cycle. The heat soak, or heat hold, allows both the kiln and glass to completely stabilize before continuing to the specified high temperature. The cooling soak or hold (also called the pre-annealing soak), commonly at about 975°F to 1000°F degrees allows stress built up in the cooling glass to be released slowly. Without the cooling soak, the glass could retain stress, resulting in breaks.

Program Modes

The EZ-Pro Deluxe controller allows the operator to select 1 of 6 program modes for different glass art/ceramics or craft applications.

The program mode is prompted on the controller display when the controller is turned on. The 6 available modes are

- 90-** For 90 COE glass projects
- 96-** For 96 COE glass projects
- bEAd** For bead annealing projects
- CLA** For METAL CLAY (Precious Metal Clay) projects
- COnE** For Ceramics projects
- USr** For custom firings

To change the program mode the controller display should be showing the **IdLE** message. (When the kiln is first turned on, the **IdLE** message should appear after about 5 seconds.) Press and hold the Increase button for about 7 seconds until the display shows the code CFG. Release the Increase button and press the Program button to view the CFG code alternating with the current mode setting. Press the Increase or Decrease buttons to select a new mode setting. When the desired mode appears on the controller display, press the Program button to return the controller display to the **IdLE** message. The new program mode can be confirmed by turning the controller off and back on to view the new start up message.

Changing Program Modes

All program edits and custom firing schedules are saved in the controller memory. If you change the Program Mode, the edits you have saved in one Program Mode will not be reset or erased. All program changes will be available the next time you return to the same Program Mode.

Selecting the Firing Schedule or Programs

After selecting a Program Mode, to select any of the available programs, first press the Program button when the display shows **IdLE**. The last used program will be the first choice on the controller display. If a different program is desired, press the Increase button to see another program. Then press the Program button again when the displays shows the program code you want. The available programs will be in the order below;

→ Preset Programs → PrO1 → PrO2→ PrO3→ PrO4→

After selecting a program continue to press the Program button to step through the program settings (each setting can be changed if desired by pressing the increase or decrease buttons to edit the values), at the end of the program settings, the display will show the message **Strt**. Press the Program button again to start the firing, the controller display will show the message **-On-**.

To stop a firing after it has been started. Press the Program button and the controller display will show **StOP**. Press the Program button again to return to the **IdLE** message.

-90- Program Mode

The 90 COE mode provides 4 preset firing schedules for glass forming and 4 optional User Programs for creating custom firing schedules. The 4 preset programs are recommended firing schedules that can also be customized if necessary. These programs provide the various heating and cooling steps for easy selection.

Full Fuse Displayed as **FUSE**

This program heats at 300F/hour to 1250F and holds this temperature for 30 minutes. Then heats at 600F/hour to 1480F and holds this temperature for 10 minutes. Then cools rapidly to 960F and holds this temperature for 40 minutes. Then cools at 150F/hour to 700F and shuts off.

Tack Fuse Displayed as **tAC**

This program heats at 300F/hour to 1250F and holds this temperature for 30 minutes. Then heats at 400F/hour to 1350F and holds this temperature for 10 minutes. Then cools rapidly to 960F and holds this temperature for 60 minutes. Then cools at 100F/hour to 700F and shuts off.

Slump Displayed as **SLP**

This program heats at 300F/hour to 1270F and holds this temperature for 15 minutes. Then cools rapidly to 960F and holds this temperature for 60 minutes. Then cools at 100F/hour to 700F and shuts off.

Fire Polish Displayed as **POL**

This program heats at 300F/hour to 1180F and holds this temperature for 10 minutes. Then cools rapidly to 960F and holds this temperature for 60 minutes. Then cools at 100F/hour to 700F and shuts off.

Program	Rate	Temp	Hold
FUSE	300°F/hour	1250F	00.30
	600°F/hour	1480F	00.10
	FULL	960F	00.40
	150°F/hour	700F	00.00
tAC	300°F/hour	1250F	00.30
	400°F/hour	1350F	00.10
	FULL	960F	01.00
	100°F/hour	700F	00.00
SLP	300°F/hour	1270F	00.10
	FULL	960F	01.00
	100°F/hour	700F	00.00
POL	300°F/hour	1180F	00.10

FULL	960F	01.00
100°F/hour	700F	00.00

The preset 90 COE programs can be edited. Each program segment can be changed by the operator. To restore the factory values, enter a zero value for the first **rA1** segment of each program and press the Program button.

In addition to the 90 COE preset programs, the -90- mode provides 4 User defined programs for custom firing schedules. Each user defined program can be up to 8 steps. The User programs are;

<u>Program</u>	<u>Rate</u>	<u>Temp</u>	<u>Hold</u>
PrO1	Undefined	Undefined	Undefined
PrO2	Undefined	Undefined	Undefined
PrO3	Undefined	Undefined	Undefined
PrO4	Undefined	Undefined	Undefined

-96- Program Mode

The 96 COE mode provides 4 preset firing schedules for glass forming and 4 optional User Programs for creating custom firing schedules. The 4 preset programs are recommended firing schedules that can also be customized if necessary. These programs provide the various heating and cooling steps for easy selection.

Full Fuse Displayed as **FUSE**

This program heats at 300F/hour to 1220F and holds this temperature for 30 minutes. Then heats at 600F/hour to 1465F and holds this temperature for 10 minutes. Then cools rapidly to 960F and holds this temperature for 40 minutes. Then cools at 100F/hour to 800F and shuts off.

Tack Fuse Displayed as **tAC**

This program heats at 300F/hour to 1250F and holds this temperature for 30 minutes. Then heats at 400F/hour to 1310F and holds this temperature for 10 minutes. Then cools rapidly to 960F and holds this temperature for 60 minutes. Then cools at 100F/hour to 800F and shuts off.

Slump Displayed as **SLP**

This program heats at 300F/hour to 1250F and holds this temperature for 15 minutes. Then cools rapidly to 960F and holds this temperature for 60 minutes. Then cools at 150F/hour to 800F and shuts off.

Fire Polish Displayed as **POL**

This program heats at 300F/hour to 1165F and holds this temperature for 10 minutes. Then cools rapidly to 960F and holds this temperature for 60 minutes. Then cools at 100F/hour to 800F and shuts off.

Program	Rate	Temp	Hold
FUSE	300°F/hour	1220F	00.30
	600°F/hour	1465F	00.10
	FULL	960F	00.40
	100°F/hour	800F	00.00
tAC	300°F/hour	1250F	00.30
	400°F/hour	1310F	00.10
	FULL	960F	01.00
	100°F/hour	800F	00.00
SLP	300°F/hour	1250F	00.15
	FULL	960F	01.00
	150°F/hour	800F	00.00
POL	300°F/hour	1165F	00.10
	FULL	960F	01.00
	100°F/hour	800F	00.00

The preset 96 COE programs can be edited. Each program segment can be changed by the operator. To restore the factory values, enter a zero value for the first **rA1** segment of each program and press the Program button.

In addition to the 96 COE preset programs, the -96- mode provides 4 User defined programs for custom firing schedules. Each user defined program can be up to 8 steps. The User programs are;

Program	Rate	Temp	Hold
PrO1	Undefined	Undefined	Undefined
PrO2	Undefined	Undefined	Undefined
PrO3	Undefined	Undefined	Undefined
PrO4	Undefined	Undefined	Undefined

bEAd Program Mode

The bEAd mode provides 3 preset firing schedules for bead annealing and 4 optional User Programs for creating custom firing schedules. The 3 preset programs are recommended firing schedules that can also be customized if necessary. These programs provide the various heating and cooling steps for easy selection.

½” beads batch annealing Displayed as **bd 1**

This program heats at 500F/hour to 980F and holds this temperature for 5 minutes. Then cools at 300F/hour to 670F and shuts off.

1” beads batch annealing Displayed as **bd 2**

This program heats at 400F/hour to 980F and holds this temperature for 10 minutes. Then cools at 150F/hour to 670F and shuts off.

2” beads batch annealing Displayed as **bd 3**

This program heats at 300F/hour to 980F and holds this temperature for 20 minutes. Then cools at 100F/hour to 670F and shuts off.

Continuous Annealing as you Create Displayed as **bd 4****

This program heats rapidly to 960F and holds this temperature for 4 hours. Then rapidly reheats to 960F to ensure stable annealing temperature and holds for 1 hour. Then cools at 600F/hour to 400F and shuts off. **This program should only be used in kilns with a properly installed bead door to ‘garage’ hot projects.

Program	Rate	Temp	Hold
Bd 1	500°F/hour	980F	00.05
	300°F/hour	670F	00.00
Bd 2	400°F/hour	980F	00.10
	150°F/hour	670F	00.00
Bd 3	300°F/hour	980F	00.20
	100°F/hour	670F	00.00
Bd 4**	FULL	960F	04.00
	FULL	960F	01.00
	600°/hour	400F	00.00

The preset bead programs can be edited. Each program segment can be changed by the operator. To restore the factory values, enter a zero value for the first **rA1** segment of each program and press the Program button.

In addition to the bead preset programs, the bEAd mode provides 4 User defined programs for custom firing schedules. Each user defined program can be up to 8 steps. The User programs are;

Program	Rate	Temp	Hold
PrO1	Undefined	Undefined	Undefined
PrO2	Undefined	Undefined	Undefined
PrO3	Undefined	Undefined	Undefined
PrO4	Undefined	Undefined	Undefined

CLA Program Mode

The CLA mode provides 5 preset firing schedules for METAL CLAY firing and 4 optional User Programs for creating custom firing schedules. The 5 preset programs are recommended firing schedules that can also be customized if necessary. These programs provide the various heating steps for easy selection.

PMC+ Fast Displayed as **P-FS**

This program heats as fast as possible to 1650°F and holds this temperature for 10 minutes.

PMC+ Slow Displayed as **P-SL**

This program heats at 1500°F/hour to 1470°F and holds this temperature for 30 minutes.

PMC3 Slow Displayed as **P3SL**

This program heats at 1500°F/hour to 1110°F and holds this temperature for 45 minutes.

PMC Standard Displayed as **Std**

This program heats as fast as possible to 1650°F and holds this temperature for 2 hours.

PMC Gold Displayed as **GOLd**

This program heats as fast as possible to 1290°F and holds this temperature for 90 minutes.

<u>Program</u>	<u>Heating Rate</u>	<u>Temp</u>	<u>Hold</u>
P-FS	Full Power	1650F	00.10
P-SL	1500°F/hour	1470F	00.30
P3SL	1500°F/hour	1110F	00.45
Std	Full Power	1650F	02.00
GOLd	Full Power	1290F	01.30

The preset METAL CLAY programs can be edited. Each program segment can be changed by the operator. To restore the factory values, enter a zero value for the first **rA1** segment of each program and press the Program button.

In addition to the METAL CLAY preset programs, the CLA mode provides 4 User defined programs for custom firing schedules. Each user defined program can be up to 8 steps. The User programs are;

<u>Program</u>	<u>Rate</u>	<u>Temp</u>	<u>Hold</u>
PrO1	Undefined	Undefined	Undefined
PrO2	Undefined	Undefined	Undefined
PrO3	Undefined	Undefined	Undefined
PrO4	Undefined	Undefined	Undefined

Ceramics Program Mode

Cone-firing Programs

The Cone-firing programs are preset firing schedules for ceramics. These firing schedules are based on Orton self-supporting cones. The various heating steps for individual cone numbers are preprogrammed for easy selection. You can fire to a predetermined Cone

schedule by simply setting the Cone number value along with an optional Speed and Hold setting. The Cone schedules are listed in the back of this manual page 55. If your controller does not allow for all the Cone-fire programs from Cone 022 to Cone 10, it has been factory set by the supplier for a limited temperature range. This is often necessary for special applications.

The COnE mode provides 1 preset firing schedule and 4 optional User Programs for creating custom firing schedules. See below for the display prompts and other information.

CFG Display		Cone Number
COnE	Default	06
Pr01		User Program
Pr02	Optional	User Program
Pr03	Optional	User Program
Pr04	Optional	User Program

Cone-Fire Speed

If you select a Cone-firing program, you will be given the option of selecting one of 3 firing speeds. These are Fast [**FAST**], Medium [**≡Ed**] and Slow [**SLO**]. The Medium speed performs all the standard heating rates as listed in the Cone-firing schedules in the back of this manual. Selecting the Fast speed increases all the program heating rates except the final heating rate by 20%. This can be used when the kiln load is very light. Selecting the Slow speed decreases all the program heating rates except the final heating rate by 20%. This can be used when the kiln load is very heavy.

The standard heating rates for Cone programs can be adjusted by the Speed setting. During programming the display prompt for the Speed setting is **SPd**. The controller will display the message **SPd** alternating with the current Speed setting immediately following the Cone Value selection. Three Speeds are available for selection.

Spd		Speed
FAST		20% Faster
≡Ed	Default	Standard
SLO		20% Slower

Cone-Firing Hold

If you select a Cone-firing program, you will be given the option of setting a final temperature Hold Time. Hold time for Cone-firing programs occur only during the final Cone temperature before completing the firing cycle. This can be used to adjust the amount of heat-work on the ware.

Hold Time is entered in Hours & Minutes format. The middle decimal point light on the controller display is used to separate Hours from Minutes. For Example, a 1 hour hold time should be set as [01.00], while a 1 hour and 30 minute hold time would be [01.30]. If no hold time is desired, the setting should be [00.00]. The value range available for setting Hold time is 00.00 to 99.59

During a firing, the hold time begins as soon as the temperature reaches the final Cone temperature. As the hold time progresses, the controller display will count-down the remaining time until the hold time has expired.

During programming the display prompt for the Hold is **HLd**. For more on Hold Times see page 24.

EZ-PRO DELUXE CONTROLLER-CONTINUED

User Program Mode

The USr mode provides 6 User Programs for creating custom firing schedules. You can store/save up to 6 separate custom firing programs in the controller memory. Each program can be up to 8 Steps long. During programming the display prompts for the individual firing schedules are **PrO1, PrO2, PrO3, PrO4, PrO5 and PrO6**.

Programming Heating and Cooling Rate

Each step of a firing program must have a programmed Rate of temperature increase or decrease. This is the speed of the heat-up or cool-down. These rate values are selected as Degrees per Hour. 'Degrees per hour' rate can be determined by dividing the total amount of temperature change by the number of hours required to achieve the temperature change. For Example, If you want to heat the kiln to 900°F from room temperature (72°F) in 2 hours time. The heating rate would be 414 Degrees/hour. [900-72 = 828, 828/2 = 414]

During programming the display prompts for all Rate settings is **rA** followed by the step number like **rA 1, rA 2, rA 3, etc...**

The values available for setting Rate are 0-1798°F/hour or 0-998°C/hour. If it's desired to heat or cool as fast as possible, an alternative setting is available at the beginning or end of the temperature range. This setting appears as **FULL** on the controller display.

Entering Zero for a heating or cooling rate

The controller determines where your firing program ends by the **rA** value. If zero is set for any Rate, this tells the controller that there are no more steps to your firing schedule. If additional steps had previously been saved in the active program, all steps after the zero entry will be erased. This feature can also be used to erase an entire firing program by setting the first **rA 1** value to zero.

Programming Heating or Cooling Temperatures

Each step of a firing program must have a programmed heating or cooling temperature. The controller must have at least one heating step to accept the firing program as valid (an invalid program results in a **bAdP** display alarm). A heating step is simply any step with a temperature setting that is above the current display temperature.

Cooling steps are automatically determined by the temperature value. If a heating or cooling temperature value is programmed to a lower setting than the previous heating or cooling temperature, it will be a cooling step.

During programming the display prompts for all Heating or Cooling Temperature settings is °F (or °C) followed by the step number like °F 1, °F 2, °F 3, etc...

The temperature range available for setting heating or cooling temperatures is 32-2400°F or 0-1316°C. If the controller does not allow you to program temperatures up to 2400°F/1316°C, it has been factory set by the supplier to a lower safety temperature. This is often necessary to limit the controller to the maximum operating temperature of the system.

Programming Hold Time

Each step of a firing program can have an optional Hold time. Hold time is the amount of time you want to stay at the previously determined heating or cooling temperature. Hold time is also referred to as Soak or Dwell time.

Hold Time is entered in Hours & Minutes format. The middle decimal point light on the controller display is used to separate Hours from Minutes. For Example, A 1 hour hold time should be set like [01.00], while a 1 hour and 30 minute hold time would be [01.30]. If no hold time is desired, the setting should be [00.00]

A special Hold time is available for indefinite Hold periods. If it is desired to hold the program temperature until someone manual stops the firing or manually advances the program, a hold time of [99.59] represents indefinite Hold.

The value range available for setting Hold time is 00.00 to 99.58.

During a firing, the hold time begins as soon as the temperature reaches the heating or cooling temperature. As the hold time progresses, the controller display will count-down the remaining time until the hold time has expired.

During programming the display prompts for all Hold settings is **HLd** followed by the step number like **HLd1**, **HLd2**, **HLd3**, etc...

Other Programming Notes

After a firing program is set in the controller, the values will not change or be lost when the controller is turned off.

It is not possible to back-up in the programming mode. If a mistake is made while programming a previous step, you must start over from the **IdLE** mode to make corrections.

If no buttons are pressed for 1 full minute during programming, the controller will automatically exit the program mode and return to the **IdLE** display. During a firing, if the options menu is activated for programming, the controller will return to the active display if no buttons are pressed for 1 full minute.

Delay Start Option

Prior to the active start of any firing, the controller display will show a Start prompt of **Strt**. This appears after the firing program selection and programming. If a delay start time is desired, press the Decrease/Review button to activate a delay start prompt. The display will show **dELA** alternating with the adjustable delay time in Hours & Minutes format. Use the Increase/Decrease buttons to set the Delay time and then press the Program button to return to the **Strt** prompt. When you are ready to begin the delay period, press the Program button again.

Delay time counts-down on the controller display before the actual start of the firing. When the delay time expires, the actual firing program begins automatically. The Delay time has a setting range of 00.00 (no delay) to 99.59 (99 hours. 59Minutes)

An active delay time can be canceled by pressing the Program/Start button any time during the delay count-down to begin the actual firing.

Thermocouple Offset Option

Thermocouple Offset allows you to correct the temperature display a few degrees in a positive or negative direction. This can improve the controller accuracy if the thermocouple probe is aged or if the firing results appear to be slightly under or over fired. This offset allows you to make minor adjustments to the firing temperatures without changing the programmed heating or cooling temperatures.

Prior to the active start of any firing, the controller display will show a Start prompt of **Strt**. This appears after the firing program selection and programming. If a thermocouple offset is desired, press the Increase/Skip button to activate a thermocouple offset prompt. The display will show **tCOS** alternating with the adjustable offset value. Use the Increase/Decrease buttons to set the Offset and then press the Program button when you are ready to return to the **Strt** prompt.

Thermocouple offset (**tCOS**) has a limited offset range of +/-20°F (+/-11°C). A positive correction will increase the controller display temperature by the amount selected. This will make the firing temperatures lower. A negative correction will decrease the controller display temperature by the amount selected, making the firing temperatures higher.

Program Review

Any time during an active firing, the Program Review feature can be activated to show you the complete firing schedule on the controller display. Press the Decrease button to activate the Program Review. Each segment of your firing schedule will scroll automatically on the display for a few seconds each. To cancel the Review in process, simply press any button.

Program Review can also be activated when the controller is **IdLE** or during program selection. After this type of Program Review, the controller advances directly to the **Strt** prompt. The Review can be used to bypass making any changes to the current firing schedule.

Program Recall

Program Review can be used to quickly select any firing schedule that is already programmed into the controller memory. To select a saved program, the controller should first be at the **IdLE** prompt. Press the Increase button until the display shows the desired program, then press the Decrease button to automatically load the program and to review the program settings. At the end of automatic program review, the controller will go directly to the **Strt** prompt and the firing can be started with one more press of the Program button. Only use the quick program recall to start a new firing if no changes are required for the entire firing program.

Options Menu

During an active firing, the Increase button will activate an options menu and scroll through the available options with each button press. These options allow you to make adjustments to the firing program without stopping the firing. The available options follow.

Skip Step

During an active heating, cooling or hold time, it is possible to skip ahead to the next program step. Press the Increase button to display the Skip Step prompt **SStP**. Then Press the Program button to display the current ramp or hold segment. Press the Program button again to initiate the Skip and the controller display returns to the normal firing mode. If the Decrease button is pressed, the Skip function is canceled and the controller display returns to the normal firing mode.

The Skip function can be used to end a Hold time early or to skip from any heating/cooling step to the next heating/cooling step. The Skip function does nothing during the final program step. To end a final program step, simply press Stop.

Add Hold Time

During an active heating, cooling or hold time, it is possible to add more Hold time to the current program step. Press the Increase button until the Hold Time prompt **HLdt** is displayed. Then Press the Program button to display the current hold time. Press the Increase button to add 5 minute increments to the original Hold time. Then Press Program button to return to the normal firing mode. If the Decrease button is pressed while the **HLdt** prompt is displayed, the controller display returns to the normal firing mode.

Change Heating/Cooling Temperature

During an active heating, cooling or hold time, it is possible to change the heating or cooling temperature of the current program step. Press the Increase button until the Change Temperature prompt **CHGt** is displayed. Then Press the Program button to display the current temperature setting. Adjust the temperature setting with the Increase

or Decrease buttons. Then Press Program button to return to the normal firing mode. If the Decrease button is pressed while the **CHGt** prompt is displayed, the controller display returns to the normal firing mode.

Threshold Alarm

During the firing, it is possible to set an audible alarm and display alarm for when the actual temperature reaches a specified value. The buzzer will sound for 30 seconds and the display will show the alarm code **ALAr**.

To set the alarm, Press Increase button during the active firing until the alarm prompt **ALAr** is displayed. Then Press the Program button to display the current alarm temperature setting. Adjust the temperature setting with the Increase or Decrease buttons. Then Press Program button to return to the normal firing mode. If the Decrease button is pressed while the **ALAr** prompt is displayed, the controller display returns to the normal firing mode.

The alarm is disabled (turned off) when the alarm value is set to 32°F (0°C). The alarm value can be reset or changed many times during a single firing. To silence an active alarm, simply press any button. The maximum programmable value for the alarm is 2400°F (1316°C). If the controller does not allow you to program alarm temperatures up to 2400°F/1316°C, it has been factory set by the supplier to a lower safety temperature. This is often necessary to limit the controller to the maximum operating temperature of the system.

Flow Diagram for Options Menu

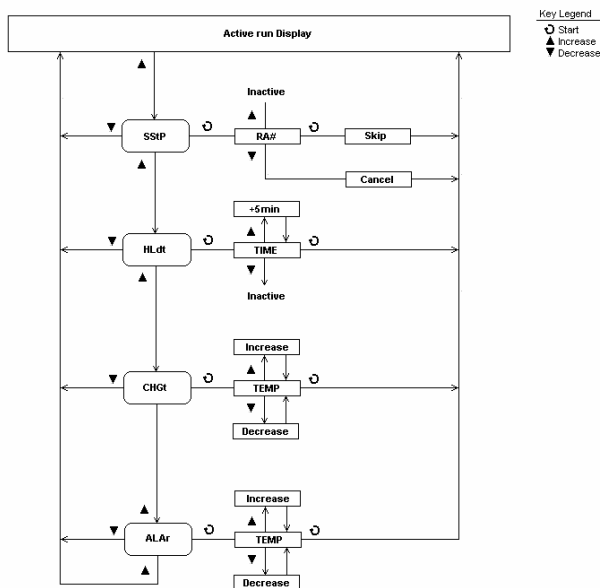

Power Fail Recovery

A firing will resume after a power interruption if certain conditions are met.

1. The controller was not performing a cooling step and the cooling temperature was not exceeded. If so, the display will show the alarm code **PF 1** and terminate the firing.
2. When power is restored the actual temperature must be above 212°F (100°C). If not, the display will show the alarm code **PF 2** and terminate the firing.
3. When power is restored, the temperature drop during the power interruption must be less than 72°F (40°C). If not, the display will show the alarm code **PF 3** and terminate the firing.

Status Display Codes

Below is a list of normal display codes which indicate the controller mode of operation.

IdLE - This is ready mode; No firing in process. This message will alternate with the temperature display and/or any alarm messages that may occur.

dELA - This is the delay start mode. This message will alternate with the delay time count-down if programmed.

Strt - This is a final prompt before starting a new firing. The Delay start and thermocouple offset features are accessed from this prompt.

-On- - This is a short (5 second) display that indicates a new firing has been started.

StOP - This is an Abort message; the firing was stopped early. This message will alternate with the temperature display and/or any alarm messages that may occur.

CPLt - This is a firing complete message; the firing ended successfully. This message will alternate with the temperature display and the total firing time from start to finish.

-90-, -96-, bEAd, CLA, COnE, USr - This is a short (5 second) display of the Program Mode which appears every time the controller is turned on.

Alarm Display Codes

In addition to Power failure alarms, these messages may be displayed if the controller detects a problem during the firing.

tC - This alarm will appear when the kiln is idle and indicates that the thermocouple sensor is no longer detected. The controller can not operate without a thermocouple signal. In most cases, the thermocouple has failed and will need replacement, or the electrical connections for the thermocouple may be loose or damaged. Check the wiring for the thermocouple and the physical condition of the probe inside the firing chamber.

tCr - This alarm will appear during and achieve firing and indicates that the thermocouple sensor is detected but the signal is reversed. The firing was terminated. The thermocouple signal is a low voltage direct current with +/- polarity. The controller will sense that the temperature is traveling backwards from what is expected. In most cases, this indicates that the thermocouple needs to be reconnected properly. Check the wiring for the thermocouple.

FAIL - This alarm indicates that the thermocouple sensor is no longer detected. The signal was lost and the firing was terminated. The controller can not operate without a thermocouple signal. In most cases, the thermocouple has failed and will need replacement, or the electrical connections for the thermocouple may be loose or damaged. Check the wiring for the thermocouple and the physical condition of the probe inside the firing chamber.

FtL - This alarm indicates that the firing was taking too long to complete and the firing was terminated. The controller monitors the deviation from the desired firing schedule as compared with the actual firing results. There are 2 conditions for the **FtL** alarm.

1. The heating or cooling rate is slower than 27°F (15°C) per Hour
2. The current program step has lasted 2 hours longer than anticipated.

In most cases, the **FtL** alarm occurs during heating if the heating rate is set to a fast speed that cannot be maintained by the kiln. If the heating rate is within the systems capability, a component failure has probably occurred with the heating elements or the heater relays.

During cool-down, a well insulated system will have cooling limitation and rapid cooling rates may set off this alarm if the cooling speed cannot be maintained. Increasing the final cool-down temperature or slowing the programmed cooling rate can avoid this alarm.

tCL - This alarm indicates that the thermocouple signal is not responding to the demand for more system power during heat-up. There are 3 conditions for the **tCL** alarm.

1. The heating rate is slower than 9°F (5°C) per Hour
2. The actual kiln temperature is lagging behind the desired setpoint temperature by more than 100°F (56°C).
3. The actual temperature is less than 500°F (260°C)

In all cases, the **tCL** alarm occurs during heating when little temperature rise is detected. This can be the result of a component failure; most likely a failed heating elements or a heater relay. Another possible problem is with the thermocouple sensor signal; if the thermocouple probe is not properly positioned in the firing chamber or if the wiring from the thermocouple has short-circuited the controller will not detect actual temperature changes in the firing chamber.

EtH - This alarm indicates that the Electronics temperature is too hot for controller operation. The controller temperature must be below 176°F (80°C) to prevent damage to the electronic components. The **EtH** alarm cannot be cleared unless the board temperature has cooled. If the **EtH** occurs frequently, check the kiln for heat loss near the controller. Proper venting and heat-shielding should be inspected.

HtdE -The High Temperature deviation alarm sounds an audible alarm and terminates the firing if the actual kiln temperature is above the controller set-point by 56°C (100°F). This alarm is active only when the actual kiln temperature is above 500°F (260°C)

FE # - Fatal software Errors, FE Alarms indicate a hardware failure or software problem with the controller. These alarms will disable the normal controller operation and require corrective action. If a Fatal Error occurs during an active firing, the firing is terminated. These alarms include;

- FE 1 – Failed to read or write to memory device
- FE 2 – Failed memory test during power on
- FE 3 – Corrupt data found in memory
- FE 4 – Errors detecting thermocouple input signal
- FE 5 – Software Execution failed

Turn the controller off and back on, then press any button to try and clear the alarm. If the alarm reoccurs immediately or frequently, the controller may require service or replacement.

FE 4 alarms can often be solved by correcting problems with the system thermocouple. Loose connections or faulty thermocouple wiring or a faulty thermocouple can result in this alarm.

Wiring Diagram

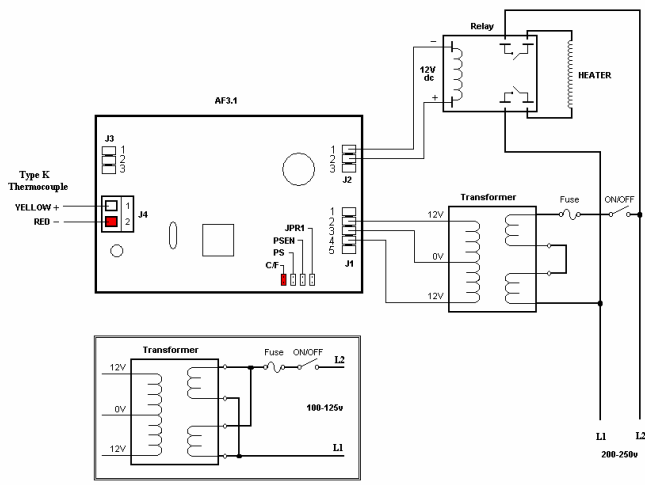

Special Note

If your kiln is set up in an unheated area, and is left idling overnight, and the room temperature has dropped to, say, 20 degrees, you may see an alarm code **TcR** (thermocouple reversed) when you attempt to run a new firing in the morning. Merely shut off the kiln and re-start. Things should then function normally.

FUSED GLASS PROJECTS

Working with Tested Compatible Glasses

To ensure success when fusing glass, use glass that has been pre-tested by the manufacturer

How to prepare your glass project

- Select glass that is “tested compatible” and has the same COE (Coefficient of Expansion) for the entire project.
- Glass projects should be comprised of two or more layers of glass from edge to edge because at a full fuse, glass likes to be approximately ¼” (6mm) thick. The best designs are constructed using a single piece of glass for the base piece, with a cut design as the second layer. If you’d like you can add more detail to your design with frit, stringers, and confetti. During assembly, take the time to make sure your glass pieces fit well together. If necessary, use a glass grinder to aid with the fit. A helpful tip to reducing and eliminating grinder marks from showing up in your fused pieces is to use an extra fine grit grinder bit.
- Oil from your glass cutter, as well as oil from your fingers while handling the pieces, is left on the surface of the glass. Thoroughly clean your glass pieces with either a light detergent, like Dawn dishwashing detergent, and water or with denatured alcohol. If you did any heavy grinding, also use a soft bristled brush, like an old toothbrush, to scrub the edges and remove any residual ground glass debris. After the glass had been cleaned and dried well, only handle it by the edges when assembling your project.
- To make transporting your project between your workspace and the kiln easier, you can use water soluble glue. Use glue very sparingly on the backside of the glass. Allow the glue to completely dry before you try to move your piece.
- Before setting up your glass projects on the kiln shelf, first place the kiln shelf in the kiln. If you are planning to fire more than one piece at a time, make sure to position your glass projects no closer than ¾” to 1” to each other and also no closer to the edge than ¾”.

Firing your Glass Project

When you first start fusing, the entire process may seem to be complicated, but it’s really simpler than it may have originally sounded. Fusing is all about controlled heating and cooling of glasses in a kiln. As glass is being fired in a kiln it goes through many physical changes based on the temperature zone that it’s in.

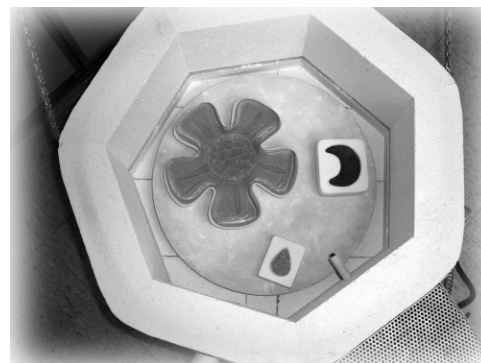

- Below 1000°F (538°C), glass is very rigid and is very susceptible to thermal shock, or breaking, if heated or cooled too quickly. Visually, the glass appears to be very rigid and it will look the same as if it were room temperature. Resist the temptation to open the kiln and peek inside, because glass is very fragile at this point and large temperature swings in the kiln will cause the glass to break.

- Between 1000°F and 1250°F (538°C – 677°C), the glass is softening, becoming more pliable, and starting to act more like a liquid and less like a solid. At the top end of this temperature range, glass will slump if held for a period of time. Visually the top layer of the glass will begin to soften and round over on the edges and the sides will start to become wet and glossy looking, or fire polished. At this point, the layers of glass haven't begun to stick together yet.
- Between 1250°F and 1350°F (577°C - 732°C), the glass is becoming even softer, and at the top end of this range will be fully slumped. It's not recommended to exceed 1350 F if you are slumping because at higher temperatures, there is a loss of control of the glass and it may slide down too far or unevenly into the mold. Visually the edges have softened and rounded even more and the surface is very glossy. If your project is held for an extended period of time in this temperature zone, it will be more prone to devitrify. Devitrification is the compositional change of the glass from an amorphous material to a more crystalline structure. As the molecules crystallize, devitrification appears to cloud the surface of the glass.
- Between 1350°F and 1400°F (732°C – 760°C), the glass will have very round edges on the surface and will stick together and become fully tack fused.
- Between 1400°F and 1500°F (760°C – 816°C) the glass becomes more fluid and fully melts together at the higher end of this temperature range, which is a full fuse.

Firing Process

In fusing, the fired appearance of the glass is referred to as the firing process for the purpose of a selecting a firing schedule.

Full Fuse: The glass has been completely melted together into one solid piece of glass that is smooth on the surface and all of the edges are well rounded.

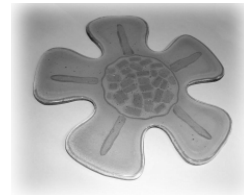

Tack Fuse: Glass has a textural feel on the surface. All the edges of the surface pieces are well rounded and fully attached to the base glass.

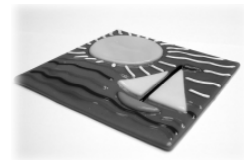

Slumping: The glass has been placed onto a mold and bent to shape and conform to the mold.

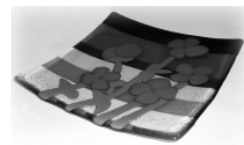

Fire polish: All surfaces of the glass have been fired to a glossy finish, yet the outside edges of the piece are crisp, clean, and somewhat square.

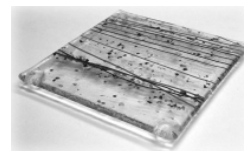

Firing stages

Initial Heating from Room Temperature (room temperature to 1200°F range):

During the initial heating, the glass is very brittle and susceptible to breaking (thermal shock) if it's heated up too quickly. During this stage, it's best to take a conservative approach and slowly heat up the glass. At the end of this range, it's a good idea to add a heat soaking period to allow the project to equalize to the same temperature throughout. Never peek in the kiln during this stage, or you risk thermal shock breakage.

Process Heating (1200°F to 1500°F range): The glass becomes softer and more fluid. During the process heating stage, the glass can be fired more quickly to the target temperature and soaked only long enough to achieve the desired look. It's important not to hold the project at these temperatures for a long period of time, or you run the risk of devitrification. (a visible clouding of the glass surface due to crystallization)

Fast Cooling (1500°F to 1100°F range): After the finished look has been achieved, it's important to cool the inside of the kiln and the glass as quickly as possible to stop the firing action so that it "freezes". During the fast cooling stage, the surface of the glass is cooler and it has contracted more than the heated center which remains expanded, thus introducing stress into the glass piece.

Annealing (1100°F to 700°F range): At the beginning of the annealing stage, it's necessary to heat soak the glass for an extended period of time to allow the glass to equalize in temperature throughout and release the stress that's in the glass. This makes the glass more stable. Then the glass is slowly cooled through the annealing temperature range to better ensure the glass piece is free of internal stresses and is physically stronger. **NEVER OPEN THE KILN DURING THIS STAGE!**

Cooling to Room Temperature (700°F to room temperature range): After the glass temperature has cooled below the annealing temperature zone, the kiln can be turned off to allow it to cool at it's own pace to around 150°F – 200°F. Again, to avoid thermal shock, do not open the kiln until it has cooled down to at least 200°F. Even at this temperature, the glass is very hot, so do not attempt to pick it up in your bare hands. Simply open up the lid of your kiln and allow the glass and the kiln shelf to cool down to room temperature.

Factors to consider before selecting a firing schedule

First envision what you want your finished piece to look like and ask yourself the following questions:

- What is the size (diameter) of the piece? How many layers thick will it be?
- What is the desired finished look?
- Will it be a full fuse, a more textural tack fuse, a combination of both?
- Will it be slumped or draped to become a more 3 dimensional and possibly functional piece?
- Will it be embellished with any surface decorations like enamels or metallic paints?

The size of your project is defined by both the diameter of the piece as well as the number of layers of glass. Glass as a material is a very poor heat conductor. The larger or thicker your project is, the more slowly it needs to be fired so that the glass has more time to heat or cool evenly all of the way through.

Imagine that you are going to bake a cake. You have set your oven on preheat to heat it up quickly, put the cake into the oven to bake, and forgot to change the dial setting to bake. When the timer goes off, you look in the oven and discover that the cake is overcooked and possibly burned on the edges, yet the center is still sunken and uncooked.

It's just the same for glass. If you heat the glass too quickly, the edges may be fused to the desired finish you like, but the center hasn't finished fusing. One solution would be to soak the piece at the process temperature for a longer period of time, but you are also taking the risk that devitrification (visible clouding due to crystallization) on the surface or that the edges will over fire and have an unusual appearance.

Another possible scenario is that the edges of the glass have melted more quickly, trapping a large amount of air in the center of the piece which expands into large bubbles within the glass, thus distorting the design.

Both scenarios could have been avoided simply by slowing down the firing program.

Think about your finished piece again. You are creating a 10" bowl that will have a full fused appearance with some added textural design elements that will be added using liquid stringer. The finished appearance will also have Hanovia gold added as accents and be slumped into a 10" bowl mold.

Seldom can a fused piece be finished in one firing. It's usually necessary to fire your piece multiple times in order to achieve the finished look that you have envisioned. With this in mind, make a list of the steps that you will need to do to create this piece, then organize them in order by process temperature from the hottest to the coolest.

<u>Process</u>	<u>Process Temperature</u>	<u>Program</u>
Full Fuse	~ 1470°F	FUSE
Liquid Stringer	~ 1350°F	tAC
Slumping	~ 1250-1275°F	SLP
Hanovia Gold	~ 1180-1200°F	POL

By order of process, the full fuse is the hottest process and will be the first firing, followed by 3 different firings to create your original glass art piece.

FIRING YOUR 90 COE GLASS PROJECT

Please note: All of the pre-programmed firing schedules are based on the slowest firing schedule for large projects. These programs can be used for all of your glass fusing regardless of project size.

Begin in the IDLE mode

To begin programming the kiln, it must be in the **IdLE** mode. This can be determined by viewing the LED display. The display will alternately display both the current temperature and the **IdLE** message. When the kiln controller is first turned on, it will display the current firing configuration that it is in.

Press (Program) button to return to the **IdLE** mode.

Select the firing configuration

To determine the current firing configuration:

Press (Increase) button and hold until the LED display shows **CFG**

Press (Program) button to display the current firing configuration.

To select the correct firing configuration,

Press (Increase) button to scroll to the correct configuration,

-90- 90 COE glass

Press (Program) button to select this configuration.

Once completed the LED display will return to the **IdLE** mode.

Select the firing program

To select correct firing program:

Press (Program) button to display the current firing program

Press (Increase) button to scroll to the correct program for your project

FUSE Full Fuse
tAC Tack Fuse
SLP Slumping
POL Fire Polishing

Press (Decrease) button to engage the correct firing program and the LED light beside "Review" will light up. Additionally, the firing program will begin to display on the LED display beginning with **rA 1**. Once the review has been completed, the display will show **Strt**.

Press (Program) button and the display will show **-On-** and begin firing. Note: If you accidentally selected the wrong program or would like to stop the program, press (Program) button again and the display will show **Stop**.

Once the kiln has completed firing, the display will show **CPLt** and this message will alternate with the temperature display and the total firing time from start to finish. **DO NOT** open the kiln until it has completely cooled and the temperature shows room temperature.

FIRING YOUR 96 COE GLASS PROJECT

Please note: All of the pre-programmed firing schedules are based on the slowest firing schedule for large projects. These programs can be used for all of your glass fusing needs regardless of project size.

Begin in the IDLE mode

To begin programming the kiln, it must be in the **IdLE** mode. This can be determined by viewing the LED display. The display will alternately display both the current temperature and the **IdLE** message. When the kiln controller is first turned on, it will display the current firing configuration that it is in.

Press (Program) button to return to the **IdLE** mode.

Select the firing configuration

To determine the current firing configuration:

Press (Increase) button and hold until the LED display shows **CFG**

Press (Program) button to display the current firing configuration.

To select the correct firing configuration,

Press (Increase) button to scroll to the correct configuration,

-96- 96 COE glass

Press (Program) button to select this configuration.

Once completed the LED display will return to the **IdLE** mode.

Select the firing program

To select correct firing program:

Press (Program) button to display the current firing program

Press (Increase) button to scroll to the correct program for your project

FUSE Full Fuse
tAC Tack Fuse
SLP Slumping
POL Fire Polishing

Press (Decrease) button to select the firing program and once selected the LED light beside "Review" will light up. Additionally, the firing program selected will begin to display on the LED display beginning with **rA 1**. Once the review has been completed, the display will show **Strt**.

Press (Program) button and the display will show **-On-** and begin firing. Note: If you accidentally selected the wrong program or would like to stop the program, press (Program) button again and the display will show **Stop**.

Once the kiln has completed firing, the display will show **CPLt** and this message will alternate with the temperature display and the total firing time from start to finish. **DO NOT** open the kiln until it has completely cooled and the temperature shows room temperature.

ANNEALING GLASS BEADS

About these annealing programs

Programs 1-3 in this grouping will batch anneal glass beads made of Bullseye, System96, and Moretti (Effetre) glasses. Program 4 is set for continuous annealing while you create.



Safety First:

Never try to put a bead already on the mandrel directly into a preheated or actively firing kiln unless the kiln has a properly installed bead door. You run the risk of electrocution. To anneal beads in a kiln without a bead door refer to batch annealing below.

What is Batch Annealing?

Batch annealing is simply taking already cooled, room temperature beads, heating them to annealing temperature and cooling them through a proper annealing cycle. The beads may either still on the mandrel or previously removed from the mandrel, and should be placed on the kiln shelf so that none of the beads are touching one another.

FIRING THE KILN

Begin in the IDLE mode

To begin programming the kiln, it must be in the **IdLE** mode. This can be determined by viewing the LED display. The display will alternately display both the current temperature and the **IdLE** message. When the kiln controller is first turned on, it will display the current firing configuration that it is in.

Press (Program) button to return to the **IdLE** mode.

Select the firing configuration

To determine the current firing configuration:

Press (Increase) button and hold until the LED display shows **CFG**

Press (Program) button to display the current firing configuration.

To select the correct firing configuration:

Press (Increase) button to scroll to the correct configuration,

bEAd Glass beads

Press (Program) button to select this configuration.

Once completed the LED display will return to the **IdLE** mode.

Select the firing program

To select the correct firing program:

Press (Program) button to display the current firing program

Press (Increase) button to scroll to the correct program for your project

- bd1** Batch annealing beads up to ½" in diameter
- bd2** Batch annealing beads up to 1" in diameter
- bd3** Batch annealing beads up to 2" in diameter
- bd4**** For Continuous annealing of all beads.

Press (Decrease) button to select the firing program and once selected the LED light beside "Review" will light up. Additionally, the firing program selected will begin to display on the LED display beginning with **rA 1**. Once the review has been completed, the display will show **Strt**.

Press (Program) button and the display will show **-On-** and begin firing. Note: If you accidentally selected the wrong program or would like to stop the program, press (Program) button again and the display will show **Stop**.

Once the kiln has completed firing, the display will show **CPLt** and this message will alternate with the temperature display and the total firing time from start to finish. **DO NOT** open the kiln until it has completely cooled and the temperature shows room temperature.

**This program should only be used in kilns with a properly installed bead door to 'garage' hot projects.

FIRING METAL CLAY CLAYS (PRECIOUS METAL CLAY)

Drying Time

Allow your pieces to be completely dried before firing them in the kiln to ensure that they don't warp.

Loading the kiln

If you fire both glass and metal clay in your kiln, it is recommended that you invest in a second shelf so that you can fire only glass on the glass kiln shelf, and only metal clay silver on the other kiln shelf. After firing your metal clay piece, some of the silver particulates impregnate the kiln shelf and leave stains on the shelf's surface. If you fire glass on the very same shelf, there is a chance that glass and silver may have a reaction that will result in silver stains left permanently on the glass.



Pieces that have a flat side can be placed directly onto the kiln shelf. They can be positioned closely together, but they shouldn't touch.

Pieces that are rounded, hollow or very delicate in composition will need support while firing so they don't collapse. Pour alumina hydrate or vermiculite into an unglazed ceramic bisque bowl and carefully place the metal clay pieces onto the alumina hydrate/vermiculite. Again, they can be positioned closely together, but they shouldn't touch.

FIRING THE KILN

Begin in the IDLE mode

To begin programming the kiln, it must be in the **IdLE** mode. This can be determined by viewing the LED display. The display will alternately display both the current temperature and the **IdLE** message. When the kiln controller is first turned on, it will display the current firing configuration that it is in.

Press (Program) button to return to the **IdLE** mode.

Select the firing configuration

To determine the current firing configuration:

Press (Increase) button and hold until the LED display shows **CFG**

Press (Program) button to display the current firing configuration.

To select the correct firing configuration,

Press (Increase) button to scroll to the correct configuration,

CLA Metal Clay

Press (Program) button to select this configuration.

Once completed the LED display will return to the **IdLE** mode.

Select firing program

To select the correct firing program:

Press (Program) button to display the current firing program

Press (Increase) button to scroll to the correct program for your project

P-FS Fast Fire PMC+
P-SL Slow Fire PMC+
P3SL Slow Fire PMC3
Std Firing PMC Standard
GOLd Firing PMC Gold

Press (Decrease) button to select the firing program and once selected the LED light beside "Review" will light up. Additionally, the firing program selected will begin to display on the LED display beginning with **rA 1**. Once the review has been completed, the display will show **Strt**.

Press (Program) button and the display will show **-On-** and begin firing. Note: If you accidentally selected the wrong program or would like to stop the program, press (Program) button again and the display will show **Stop**.

Once the kiln has completed firing, the display will show **CPLt** and this message will alternate with the temperature display and the total firing time from start to finish. **DO NOT** open the kiln until it has completely cooled and the temperature shows room temperature.

Ceramics Project

To ensure success when firing ceramics, use bisque that has been fired to COnE 04 and compatible glazes. Glazes should be low-fire glazes and be able to fire at COnE 06.

How to prepare your ceramic project

- Select bisqueware that has been pre-fired to cone 04.
- Prior to painting the bisqueware use a damp sponge and wipe down. This step will get rid of any dust. Dust on the bisqueware can cause glazes not to adhere.
- Use low-fire glazes (underglaze) to decorate your bisqueware. Low fire glaze (underglaze) can be used for detailed design work or for solid covering. For solid covering 3 even coats should be applied to bisqueware.
- Most low-fire glazes (underglaze) are lead-free and to ensure that the project is dinnerware safe a clear glaze should be applied. Make sure that the clear glaze has been tested and approved as dinnerware safe.
- Clear glazes come in different finishes. Gloss, Matte, and Crackle are a few that are available. When applying clear glaze (overglaze) 3 even coats should be applied.
- Allow your project to dry prior to firing in the kiln.

Loading the kiln

- Glazed bisqueware pieces are loaded in the kiln on shelves and kiln posts.
- Make sure that a coat of kiln wash has been applied to the top side of the shelf.
- Place four short kiln posts on the bottom of the kiln to set the shelf on.
- Place your glazed pieces in the kiln making sure that they do not touch each other.
- Glazed surfaces should not touch the shelf – use shelf paper or stilts for best results.

FIRING YOUR CERAMICS PROJECT

To ensure success when firing ceramics, use bisques that have been previously fired to Cone Number 04 and compatible glaze. Glazes should be able to fire at Cone Number 06.

****Remember that kiln should be on ceramic mode (flip toggle switch).**

Begin in the IDLE mode

To begin programming the kiln, it must be in the **IdLE** mode. This can be determined by viewing the LED display. The display will alternately display both the current temperature and the **IdLE** message. When the kiln controller is first turned on, it will display the current firing configuration that it is in.

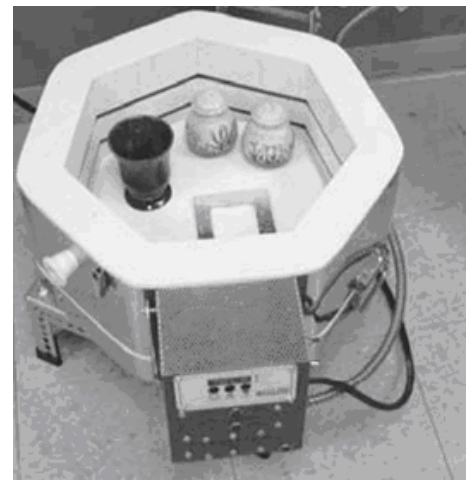

Press (Program) button to return to the **IdLE** mode.

Begin in the IdLE mode

To begin programming the kiln, it must be in the IdLE mode. This can be determined by viewing the LED display. The display will alternately display both the current temperature and the IdLE message. When the kiln controller is first turned on, it will display the current firing configuration that it is in.

Press the (Program) button. The controller will display the last active program that was used. COnE or PrO1-PrO4

Press (Program) button again if COnE is displayed or press (Increase) button until the display shows COnE then press (Program) button again.

Press the (Increase) or (Decrease) button to adjust the cone number on the display to 06. Then press (Program) button again.

Press the (Increase) or (Decrease) button to adjust the Firing Speed to Medium. Then press (Program) button again.

Once completed the LED display will return to the **IdLE** mode.

INTERMEDIATE MODE

Keeping a log

There is no “one program fits all” firing schedule for kilns. Even supposedly identical kilns behave slightly differently. Plugging the same kiln into different outlets in your house may also alter the firing schedule you need. Additionally, different size projects or different colors of glass will react differently, necessitating changes to your firing schedules. It is therefore very important for you to keep detailed firing logs whenever you do a new project or change any parameter in an existing project.

As you gain experience using your kiln, you may find that you need to use the “add hold time” or the “skip step” sequences (see page 25) to get exactly the results you want. If this is consistently the case for your particular project, you may want to generate a user program, written to your desired specifications or modify one of the pre-programmed firing schedules.

Changing Pre-Programmed Firing Programs

It's a fairly simple process to modify any of the pre-programmed firing schedules to suit your specific needs. If you are relatively new to fusing, or to the use of computer controls, however, we suggest that you read through the manual and copy one of the programs in the manual, modifying it as you desire. Once you've test fired the program a few times, you can either leave it as a user program, or use the new program as a reference to go back and modify the preset program.

In all instances, keep a log of your firings, especially when you make changes, so you'll be able to track and or troubleshoot when you have unexpected results.

Pages 16 through 23 outline the procedure for programming, or modifying the programs in the kiln.

PROFESSIONAL MODE: PROGRAMMING CUSTOM FIRING PROGRAMS

You can enter up to 22 custom firing programs in the controller for all of your firing needs. Each program can contain up to 8 steps (segments).

Special note: All changes made to both the pre-programmed and customer programs will be permanently be stored in the memory until you change them!

Configuration	Pre-Programmed	Custom Programs
-90-	4	4
-96-	4	4
bEAd	4	4
CLA	5	4
COnE	32	4
Usr	0	6

During the programming, the display prompts for the individual firing programs are **Pr** followed by the program number like **Pr01**, **Pr02**, **Pr03**, etc.

To select any of the available programs it is first necessary to be in the **IdLE** mode.

1. Press (Program) button and the last used program will be the first to come up.
2. Press (Increase) button to select the program you would like to enter or change.
3. Press (Program) button again when the display shows the firing program you want.
4. Press (Program) button to begin programming your firing schedule. The display will first prompt **rA 1** for the rate of the first segment in your program.
5. Press (Increase) or (Decrease) button to change the firing rate. If you'd like the rate to be as fast as possible, press the (Decrease) button until the display changes to **0**, then press the (Decrease) button one more time and display will change to **FULL**.
6. Press (Program) button to proceed to the set point temperature. The display will prompt **°F 1**.
7. Press (Increase) or (Decrease) button to change the set point temperature.
8. Press (Program) button to proceed to the hold time. The display will prompt **HLd1**.

9. Press (Increase) or (Decrease) button to change the hold time. Hold time is entered in Hours and Minutes. For example, a 1 hour hold time should be entered as 01.00, and a 30 minute hold will read 00.30.
10. To add additional segments, repeat steps 4-9.
11. If you are programming over an existing program that has more segments than the current program you are entering, at the beginning of the next segment, Press (Decrease) button to change the rate to 0
12. Press (Program) button to program the change, and the display will prompt **Strt.**
13. Press (Program) button to start the kiln.
14. Press (Program) button and the display will show **-On-** and begin firing. Note: If you accidentally selected the wrong program or would like to stop the program, press (Program) button again and the display will show **Stop.**

Once the kiln has completed firing, the display will show **CPLt** and this message will alternate with the temperature display and the total firing time from start to finish. DO NOT open the kiln until it has completely cooled and the temperature shows room temperature.

90 COE Pre-Programmed Firing Programs

FUSE	Segment	Rate, °/Hr	Set Point Temp	Hold/Soak Time
Full Fuse	1	300° F	1250° F	30 min
	2	600° F	1480° F	10 min
	3	Full	960° F	40 min
	4	150° F	700° F	--

TAC	Segment	Rate, °/Hr	Set Point Temp	Hold/Soak Time
Tack Fuse	1	300° F	1250° F	30 min
	2	400° F	1350° F	10 min
	3	Full	960° F	1 hr 00 min
	4	100° F	700° F	--

SLP	Segment	Rate, °/Hr	Set Point Temp	Hold/Soak Time
Slumping	1	300° F	1270° F	15 minutes
	2	Full	960° F	1 hour
	3	100° F	700° F	--

POL	Segment	Rate, °/Hr	Set Point Temp	Hold/Soak Time
Firepolish	1	300° F	1180° F	10 minutes
	2	Full	960° F	1 hour
	3	100° F	700° F	--

90 COE Custom Firing Programs

USr1	Segment	Rate, °/Hr	Set Point Temp	Hold/Soak Time
	1			
	2			
	3			
	4			
	5			
	6			
	7			
	8			

USr2	Segment	Rate, °/Hr	Set Point Temp	Hold/Soak Time
	1			
	2			
	3			
	4			
	5			
	6			
	7			
	8			

USr3	Segment	Rate, °/Hr	Set Point Temp	Hold/Soak Time
	1			
	2			
	3			
	4			
	5			
	6			
	7			
	8			

USr4	Segment	Rate, °/Hr	Set Point Temp	Hold/Soak Time
	1			
	2			
	3			
	4			
	5			
	6			
	7			
	8			

96 COE Pre-Programmed Firing Programs

FUSE	Segment	Rate, °/Hr	Set Point Temp	Hold/Soak Time
Full Fuse	1	300° F	1220° F	30 min
	2	600° F	1465° F	10 min
	3	Full	960° F	40 min
	4	100° F	800° F	--

TAC	Segment	Rate, °/Hr	Set Point Temp	Hold/Soak Time
Tack Fuse	1	300° F	1250° F	30 min
	2	400° F	1310° F	10 min
	3	Full	960° F	1 hr 0 min
	4	100° F	800° F	--

SLP	Segment	Rate, °/Hr	Set Point Temp	Hold/Soak Time
Slump	1	300° F	1250° F	15 min
	2	Full	960° F	1 hr 0 min
	3	150° F	800° F	--

POL	Segment	Rate, °/Hr	Set Point Temp	Hold/Soak Time
Firepolish	1	300° F	1165° F	10 min
	2	Full	960° F	1 hr 0 min
	3	100° F	800° F	--

96 COE Pre-Programmed Firing Programs

USr1	Segment	Rate, °/Hr	Set Point Temp	Hold/Soak Time
	1			
	2			
	3			
	4			
	5			
	6			
	7			
	8			

USr2	Segment	Rate, °/Hr	Set Point Temp	Hold/Soak Time
	1			
	2			
	3			
	4			
	5			
	6			
	7			
	8			

USr3	Segment	Rate, °/Hr	Set Point Temp	Hold/Soak Time
	1			
	2			
	3			
	4			
	5			
	6			
	7			
	8			

USr4	Segment	Rate, °/Hr	Set Point Temp	Hold/Soak Time
	1			
	2			
	3			
	4			
	5			
	6			
	7			
	8			

Bead Annealing Pre-Programmed Firing Programs

bd1	Segment	Rate, °/Hr	Set Point Temp	Hold/Soak Time
Small Beads (1/2")	1	500° F	980° F	5 min
	2	300° F	670° F	--

bd2	Segment	Rate, °/Hr	Set Point Temp	Hold/Soak Time
Medium Beads (1")	1	400° F	980° F	10 min
	2	150° F	670° F	--

bd3	Segment	Rate, °/Hr	Set Point Temp	Hold/Soak Time
Large Beads (2")	1	300° F	980° F	20 min
	2	100° F	670° F	--

bd4	Segment	Rate, °/Hr	Set Point Temp	Hold/Soak Time
Continuous Annealing as you Create	1	FULL	960° F	4 hours
	2	FULL	960° F	1 hour
	3	600° F	400° F	--

Bead Annealing Custom Firing Programs

USr1	Segment	Rate, %/Hr	Set Point Temp	Hold/Soak Time
	1			
	2			
	3			
	4			
	5			
	6			
	7			
	8			

USr2	Segment	Rate, %/Hr	Set Point Temp	Hold/Soak Time
	1			
	2			
	3			
	4			
	5			
	6			
	7			
	8			

USr3	Segment	Rate, %/Hr	Set Point Temp	Hold/Soak Time
	1			
	2			
	3			
	4			
	5			
	6			
	7			
	8			

USr4	Segment	Rate, %/Hr	Set Point Temp	Hold/Soak Time
	1			
	2			
	3			
	4			
	5			
	6			
	7			
	8			

Metal Clay Pre-Programmed Firing Programs

P-FS	Segment	Rate, °/Hr	Set Point Temp	Hold/Soak Time
PMC + Fast	1	Full	1650° F	10 min

P-SL	Segment	Rate, °/Hr	Set Point Temp	Hold/Soak Time
PMC + Slow	1	1500° F	1470° F	30 min

P3SL	Segment	Rate, °/Hr	Set Point Temp	Hold/Soak Time
PMC3 Slow	1	1500° F	1110° F	45 min

STD	Segment	Rate, °/Hr	Set Point Temp	Hold/Soak Time
PMC	1	Full	1650° F	2 hr 0 min

GOLd	Segment	Rate, °/Hr	Set Point Temp	Hold/Soak Time
PMC Gold	1	Full	1290° F	1 hr 30 min

CERAMIC Pre-Programmed Cone Firings

Cone	rA1	°F1	rA2	°F2	rA3	°F3	rA4	°F4
022	396	979	108	1087	-	-	-	-
021	396	1004	108	1112	-	-	-	-
020	396	1051	108	1159	-	-	-	-
019	396	1144	108	1252	-	-	-	-
018	396	1211	108	1319	-	-	-	-
017	396	1252	108	1360	-	-	-	-
016	396	1314	108	1422	-	-	-	-
015	396	1348	108	1456	-	-	-	-
014	396	1377	108	1485	-	-	-	-
013	396	1431	108	1539	-	-	-	-
012	396	1474	108	1582	-	-	-	-
011	396	1499	108	1607	-	-	-	-
010	324	1022	153	1112	180	1549	108	1657
09	324	1022	153	1112	180	1580	108	1688
08	324	1022	153	1112	180	1620	108	1728
07	324	1022	153	1112	180	1681	108	1789
06	324	1022	153	1112	180	1720	108	1828
05	324	1022	153	1112	180	1780	108	1888
04	324	1022	153	1112	180	1837	108	1945
03	324	1022	153	1112	180	1879	108	1987
02	324	1022	153	1112	180	1908	108	2016
01	324	1022	153	1112	180	1938	108	2046
1	324	1022	153	1112	162	1863	108	2079
2	324	1022	153	1112	162	1872	108	2088
3	324	1022	153	1112	162	1890	108	2106
4	324	1022	153	1112	162	1908	108	2124
5	324	1022	153	1112	162	1951	108	2167
6	324	1022	153	1112	162	2016	108	2232
7	324	1022	153	1112	162	2046	108	2262
8	324	1022	153	1112	162	2064	108	2280
9	324	1022	153	1112	162	2084	108	2300
10	324	1022	153	1112	162	2129	108	2345

PMC Custom Firing Programs

USr1	Segment	Rate, °/Hr	Set Point Temp	Hold/Soak Time
	1			
	2			
	3			
	4			
	5			
	6			
	7			
	8			

USr2	Segment	Rate, °/Hr	Set Point Temp	Hold/Soak Time
	1			
	2			
	3			
	4			
	5			
	6			
	7			
	8			

USr3	Segment	Rate, °/Hr	Set Point Temp	Hold/Soak Time
	1			
	2			
	3			
	4			
	5			
	6			
	7			
	8			

USr4	Segment	Rate, °/Hr	Set Point Temp	Hold/Soak Time
	1			
	2			
	3			
	4			
	5			
	6			
	7			
	8			

User Custom Firing Programs (USr)

USr1	Segment	Rate, °/Hr	Set Point Temp	Hold/Soak Time
	1			
	2			
	3			
	4			
	5			
	6			
	7			
	8			

USr2	Segment	Rate, °/Hr	Set Point Temp	Hold/Soak Time
	1			
	2			
	3			
	4			
	5			
	6			
	7			
	8			

USr3	Segment	Rate, °/Hr	Set Point Temp	Hold/Soak Time
	1			
	2			
	3			
	4			
	5			
	6			
	7			
	8			

USr4	Segment	Rate, °/Hr	Set Point Temp	Hold/Soak Time
	1			
	2			
	3			
	4			
	5			
	6			
	7			
	8			

USr5	Segment	Rate, °/Hr	Set Point Temp	Hold/Soak Time
	1			
	2			
	3			
	4			
	5			
	6			
	7			
	8			

USr6	Segment	Rate, °/Hr	Set Point Temp	Hold/Soak Time
	1			
	2			
	3			
	4			
	5			
	6			
	7			
	8			

Orton Controller Limited Warranty

This limited warranty is given only to the immediate purchaser ("Buyer") of the Autofire®Express kiln controller. This limited warranty is not transferable. The Edward Orton Jr. Ceramic Foundation ("Orton") warrants the controller motherboard installed on the Autofire®Express ("Warranted Components") to be in good working order under normal operating conditions for a period of one (1) year from the date of purchase. Should the Warranted Components fail to be in good working order at any time during the stated one (1) year period, Orton will, at its option, repair or replace the Warranted Components as set forth below. The liability of Orton is limited to replacement and/or repair at its factory of the Warranted Components that does not remain in good working order. Repair parts or replacement products will be furnished on an exchange basis and will be either reconditioned or new. All replaced parts or products become the property of Orton. Following receipt of notice from Buyer of a valid warranty claim and the Autofire®Express containing the Warranted Components, Orton will perform its obligations under this limited warranty within 10 business days.

Limited warranty service may be obtained by delivering the Autofire®Express during the warranty period to your Orton Supplier or to The Edward Orton Jr. Ceramic Foundation, 6991 Old 3C Highway, Westerville, Ohio 43082 and providing written proof of purchase and a description of the defect or problem. Buyer must insure the shipment or assume the risk of loss or damage in transit, prepay shipping charges to the service location, and use the original shipping container or equivalent. Buyer will be responsible for shipping and handling charges in excess of US \$50.00 incurred by Orton in returning the Autofire®Express to the Buyer after completion of limited warranty service.

This warranty does not apply to any damage to the Autofire®Express resulting from:

- Operation beyond electrical rating.
- External sources including, but not limited to, chemicals, heat abuse and improper care.
- Improper or inadequate maintenance by Buyer.
- Parts or equipment not supplied by Orton.
- Unauthorized modification or misuse.
- Operation outside environmental specifications.
- Improper installation.
- Over firing (melting of materials being fired) regardless of the cause of the over firing.

Warranted Components returned for service where no warranted defect is found will be subject to service, and shipping and handling fees.

If the Warranted Components are not in good working order as warranted above, Buyer's sole remedy shall be repair or replacement of the Warranted Components as provided above.

TO THE EXTENT PERMITTED BY LAW, ALL EXPRESS AND IMPLIED WARRANTIES FOR THE WARRANTED COMPONENTS INCLUDING THE WARRANTIES OF MERCHANTABILITY AND FITNESS FOR A PARTICULAR PURPOSE ARE LIMITED TO THE ONE YEAR WARRANTY PERIOD COMMENCING ON THE DATE OF PURCHASE, AND NO OTHER WARRANTY WHETHER EXPRESS OR IMPLIED WILL APPLY TO THIS PERIOD. TO THE EXTENT PERMITTED BY LAW, ORTON'S REMEDY AND BUYER'S SOLE REMEDY IS LIMITED SOLELY AND EXCLUSIVELY TO REPAIR OR REPLACEMENT AS SET FORTH HEREIN. ORTON SHALL NOT BE LIABLE FOR, AND BUYER'S REMEDY SHALL NOT INCLUDE ANY INCIDENTAL, CONSEQUENTIAL OR OTHER DAMAGES OF ANY KIND WHATSOEVER, WHETHER A CLAIM IS BASED UPON THEORY OF CONTRACT, NEGLIGENCE OR TORT.

Buyer shall determine suitability of the Autofire®Express for the intended use and assume all risk and liability therewith. Some states do not allow this exclusion or limitation of incidental or consequential damages, so the above limitation or exclusion may not apply to you. This warranty gives you specific legal rights, and you may also have other rights which vary from State to State.

The above limitation does not apply in the event that any Warranted Components are determined by a court of competent jurisdiction to be defective and to have directly caused bodily injury, death or property damage; provided that in no event shall Orton's liability exceed the greater of \$1,000.00 or the purchase price of the specific Autofire®Express that caused such damage.

Service may also be obtained on Warranted Components no longer under warranty by returning the Autofire®Express prepaid to Orton with a description of the problem and Buyer's name and contact information. Buyer will be contacted with an estimate of services charges before any work is performed.

Customer Satisfaction Policy

If for any reason you are not completely satisfied with the performance of the Orton Autofire®Express or the conditions of this warranty, return the Autofire®Express in good working condition, transportation and insurance prepaid, within 30 days of purchase date to your supplier or The Edward Orton Jr. Ceramic Foundation, 6991 Old 3C Highway, Westerville, Ohio 43082 and your purchase price will be refunded. Prior to returning your Autofire®Express contact Orton for an authorization number and include with your shipment. For controllers ordered in error, a restocking charge will apply.

Revised: October 22, 2007

JEN-KEN KILN WARRANTY

JEN-KEN KILNS are warranted to the original purchaser to be free from defects in materials and workmanship when used under normal and proper conditions for the periods specified below. The warranty period begins at the date of original purchase from **JEN-KEN KILNS**, a **JEN-KEN KILN** authorized distributor or dealer.

JEN-KEN KILNS are warranted for 2 years from date of original purchase.

Dawson Kiln Sitter is warranted by a separate 1 year warranty from WP Dawson, Inc.

AutoFire panels are warranted by a separate 1 year plan from the manufacturer.

FireRight panels are warranted by a separate 1 year plan from the manufacturer.

To Claim under the Warranty, the purchaser must:

- 1) Provide written proof of the date of purchase.
- 2) Notify **JEN-KEN KILN** (or distributor/dealer) from whom the kiln was purchased.
- 3) Make the kiln immediately available for inspection.

FOR WARRANTY REPAIRS:

- 1) Warranty repairs should be handled from where you purchased the kiln and they will arrange for any repairs or replacement of parts under the terms of the warranty and upon receipt of the kiln or defective part(s). Warranty work, other than that performed at the factory, DOES NOT include labor, just parts. The defective parts may be returned to **JEN-KEN KILNS** (postage prepaid) 3615 Ventura Drive West, Lakeland, Florida USA 33811. Include your name and address, a letter of explanation and the name and address from where you purchased the kiln. If, after factory examination the part is found to be defective, a new or repaired part will be sent prepaid by **JEN-KEN KILNS**.
- 2) If the entire kiln is to be returned to the factory, all transportation costs are the responsibility of the purchaser. The purchaser should notify **JEN-KEN KILNS** (863) 648-0585 prior to shipping. We will advise the best shipping method and if it is necessary

to return the whole kiln or only certain parts. Factory warranty work will be performed within 30 days after the defective part is returned to the factory.

- 3) **JEN-KEN KILN** reserves the right, as its option, to replace the entire kiln or any part of it in order to fulfill its obligation under this warranty.

This Warranty DOES NOT Cover:

- 1) Freight damage.
- 2) Kilns altered in any way after leaving our factory.
- 3) Abuse or neglect, moisture, improper storage.
- 4) Improper installation.
- 5) Kiln Overfires (exceeding the melting temperatures of the materials being fired) regardless of the cause of the overfire. (This does not occur in kilns that are monitored while firing. If in doubt during a firing, turn the kiln off)
- 6) Dawson Kiln Sitter or Limit Timer.
- 7) Kilns operated on incorrect voltage.
- 8) Improper electrical installation.
- 9) Kiln furniture.
 - 1) Kiln ware.
 - 2) Kilns used for purposes other than firing ceramic or glass materials.
 - 3) Kilns operated in excess of the temperature rating of the kiln.
 - 4) Damage that may occur from kilns that are fired on or near combustible materials (i.e.: wood floors).

This Warranty is in lieu of all other warranties, expressed or implied. **JEN-KEN KILN** neither assumes nor authorizes any distributor, dealer, retailer or employee to assume for it any other obligation of liabilities in connection with **JEN-KEN KILNS**.

This warranty is limited, as specified above and excludes incidental or consequential damages, so the above limitations or exclusions may not apply to you. This warranty give you specific rights and you may also have other rights why vary from state to state.

JEN-KEN KILNS

Manufactured by
Sir Ramic Porcelain, Inc.
3615 Ventura Drive West
Lakeland, Florida USA 33811
(863) 648-0585