



Orton Ceramic Foundation - 6991 Old 3C Highway, Westerville, OH 43082-9026
Phone (614) 895-2663, Fax (614) 895-5610
(www.ortonceramic.com)

Autofire® Express
Model A-4 Ramp/Hold Controller



JEN-KEN KILNS AF3P Controller

(Auto-Fire 3 Button Programmable)



**PROGRAM
START/STOP**

This button is for selecting a firing program and advancing through the programming steps. After programming is complete, use this button to Start and Stop the firing.



**INCREASE
OPTION**

This button is used to change the firing program during programming and to change the display values for specific program settings. During a firing, use this button for special firing options.



**DECREASE
REVIEW**

This button is used to change the display values for specific program settings. It is also used to activate the Program Review feature.



**INCREASE
OPTION**



**DECREASE
REVIEW**

When using the Increase and Decrease buttons to change number settings, the values will change more rapidly if the button is held in.

CONTROLLER FEATURES

<i>User Programs</i>	6 - Eight step Programs
<i>Temperature Units</i>	Fahrenheit or Celsius
<i>Program Review</i>	Displays active program
<i>Delay Start</i>	Optional to 100 hours (Never leave a firing kiln unattended)
<i>Skip Step</i>	Skips to next ramp when firing
<i>Add Time</i>	Add 5 minute increments to a hold
<i>Add Temp</i>	Adds Temperature to the set point temperature
<i>Rapid Heat/Cool</i>	Full heating or cooling rates
<i>Power Recovery</i>	Resumes after power failure
<i>Diagnostics</i>	Audible Alarm and display codes
<i>Thermocouple Type</i>	K only
<i>Maximum Temperature</i>	Factory set for 930°C /1700°F for Glass Kilns and PMC Kilns, or 1300°C / 2372°F Ceramics Kilns

Status Indicator Lights

3 red lights are located to the right of the display.

- ☐ Program lit during controller programming
- ☐ Review lit during Program Review.
- ☐ Run lit (blinks) during an active firing.

Audible Alarm

The controller is equipped with a small buzzer that will sound during button presses and at the successful completion of a firing for 30 seconds. The alarm will also sound to notify you of diagnostic alarms that may occur during a firing. To silence an active buzzer, Press any button. This alarm may be deactivated if desired.

Temperature display preference

All temperature displays on the controller can be viewed as °F (Fahrenheit) or °C (Celsius). The temperature display preference is set by positioning a small circuit board jumper on the back side of the controller that is labeled C/F. The C/F jumper has 2 pin positions, when installed on the 2 corresponding circuit board pins the controller will display all temperatures as °F(Fahrenheit). When no jumper is installed on the 2 circuit board pins the controller will display all temperatures as °C (Celsius). To determine if your controller is set for °F or °C without viewing the jumper position, the small decimal point light in the bottom right-hand corner of the display panel indicates °F or °C. If this decimal point light is lit, the controller is set for °C.

The C/F jumper position is shown on the wiring diagram included in this manual.

Temperature Measurement

The controller monitors and controls temperature from a single Type K thermocouple sensor. Thermocouple probes extend into the firing chamber to measure the temperature. Use caution to avoid damage to the system thermocouple. If the probe is damaged, the controller may not function properly.

Temperature Control

The controller heats the firing chamber by turning relays on and off at the appropriate rate to maintain the program schedule. It is normal to hear the clicking noises associated with turning relays on and off throughout the firing.

Understanding Firing Programs

Orton controllers require 3 variables for each heating or cooling segment of a firing schedule. These variables are;

1. Heating or cooling rate (Speed) Example: rA1
2. Heating or cooling temperature Example: oF1
3. Hold time (Soak) at heating or cooling temperature. Example: Hld1

A complete firing schedule can be multiple heating and/or cooling segment. However, for many applications a single segment is all that is required. The maximum number of program segments is limited to 8.

Programming Heating and Cooling Rate

Each segment of a firing program must have a programmed Rate of temperature increase or decrease. This is the speed of the heat-up or cool-down. These rate values are selected as Degrees per Hour. 'Degrees per hour' rate can be determined by dividing the total amount of temperature change by the number of hours required to achieve the temperature change. For Example, If you want to heat the kiln to 900 °F from room temperature (72 °F) in 2 hours time. The heating rate would be 414 Degrees/hour. [900-72 = 828, 828/2 = 414] Another Example, Heat at 300 °F/hour to 1200 degrees will take you 4 hours.

Degrees per minute will need to be changed to degrees per hours by multiplying by 60. Example 5 degrees/minute needs to be entered as 300 °F/hour (5 degrees/min x 60 minutes = 300 °F/hour)

During programming the display prompts for all Rate settings are **rA** followed by the step number like **rA 1**, **rA 2**, **rA 3**, etc...

FULL: The values available for setting Rate are 0-1798 °F/hour or 0-998 °C/hour. If it's desired to heat or cool as fast as possible, an alternative setting is available below 0 °F/hour or above 1798 °F/hour of the temperature range. This setting appears as **FULL** on the controller display.

Entering Zero for a heating or cooling rate

The controller determines where your firing program ends by the **rA** value. If zero is set for any Rate, this tells the controller that there are no more segments to your firing schedule. If additional steps had previously been saved in the active program, all steps after the zero entry will be erased. This feature can also be used to erase an entire firing program by setting the first **rA 1** value to zero.

Programming Heating or Cooling Temperatures

Each segment of a firing program must have a programmed heating or cooling temperature. The controller must have at least one heating segment to accept the firing program as valid (an invalid program results in a **bAdP** display alarm). A heating segment is simply any segment with a temperature setting that is above the current display temperature.

Cooling segment are automatically determined by the temperature value. If a heating or cooling temperature value is programmed to a lower setting than the previous heating or cooling temperature, it will be a cooling segment.

During programming the display prompts for all Heating or Cooling Temperature settings is °F (or °C) followed by the step number like °F 1, °F 2, °F 3, etc...

The temperature range available for setting heating or cooling temperatures is 32-2400 °F or 0-1316 °C. If the controller does not allow you to program temperatures up to 2400 °F/1316 °C, it has been factory set by the supplier to a lower safety temperature. This is often necessary to limit the controller to the maximum operating temperature of the kiln. Glass kilns are usually preset to 1700 °F max temperature.

Programming Hold Time

Each step of a firing program can have an optional Hold time. Hold time is the amount of time you want to stay at the previously determined heating or cooling temperature. Hold time is also referred to as Soak or Dwell time.

Hold Time is entered in Hours & Minutes format. The middle decimal point light on the controller display is used to separate Hours from Minutes. For Example, A 1 hour hold time should be set like [01.00], while a 1 hour and 30 minute hold time would be [01.30]. If no hold time is desired, the setting should be [00.00]. A typical 10 minute hold time for glass fusing would be [00.10].

A special Hold time is available for indefinite Hold periods. If it is desired to hold the program temperature until someone manual stops the firing or manually advances the program, a hold time of [99.59] represents indefinite Hold.

The value range available for setting Hold time is 00.00 to 99.58.

During a firing, the hold time begins as soon as the temperature reaches the heating or cooling temperature. As the hold time progresses, the controller display will count-down the remaining time until the hold time has expired.

During programming the display prompts for all Hold settings is **HLd** followed by the step number like **HLd1**, **HLd2**, **HLd3**, etc...

Other Programming Notes

After a firing program is set in the controller, the values will not change nor be lost when the controller is turned off.

It is not possible to back-up in the programming mode. If a mistake is made while programming a previous step, you must start over from the **IdLE** mode to make corrections.

If no buttons are pressed for 1 full minute during programming, the controller will automatically exit the program mode and return to the **IdLE** display. During a firing, if the options menu is activated for programming, the controller will return to the active display if no buttons are pressed for 1 full minute.

Delay Start Option

Prior to the active start of any firing, the controller display will show a Start prompt of **Strt**. This appears after the firing program selection and programming. If a delay start time is desired, press the Decrease/Review button to activate a delay start prompt. The display will show **dELA** alternating with the adjustable delay time in Hours & Minutes format. Use the Increase/Decrease buttons to set the Delay time and then press the Program button to return to the **Strt** prompt. When you are ready to begin the delay period, press the Program button again.

Delay time counts-down on the controller display before the actual start of the firing. When the delay time expires, the actual firing program begins automatically. The Delay time has a setting range of 00.00 (no delay) to 99.59 (99 hours. 59Minutes)

An active delay time can be canceled by pressing the Program/Start button any time during the delay count-down to begin the actual firing.

Never leave a firing or a delay started kiln unattended !!!

Thermocouple Offset Option

Thermocouple Offset allows you to correct the temperature display a few degrees in a positive or negative direction. This can improve the controller accuracy if the thermocouple probe is aged or if the firing results appear to be slightly under or over fired. This offset allows you to make minor adjustments to the firing temperatures without changing the programmed heating or cooling temperatures.

Prior to the active start of any firing, the controller display will show a Start prompt of **Strt**. This appears after the firing program selection and programming. If a thermocouple offset is desired, press the Increase/Option button to activate a thermocouple offset prompt. The display will show **tCOS** alternating with the adjustable offset value. Use the Increase/Decrease buttons to set the Offset and then press the Program button when you are ready to return to the **Strt** prompt.

Thermocouple offset (**tCOS**) has a limited offset range of +/-20 °F (+/-11 °C). A positive correction will increase the controller display temperature by the amount selected. This will make the firing temperatures lower. A negative correction will decrease the controller display temperature by the amount selected, making the firing temperatures higher.

Program Review

Any time during an active firing, the Program Review feature can be activated to show you the complete firing schedule on the controller display without interrupting the firing schedule. Press the Decrease/Review button to activate the Program Review. Each segment of your firing schedule will scroll automatically on the display for a few seconds each. To cancel the Review in process, simply press any button.

Program Review can also be activated when the controller is **IdLE** or during program selection. After this type of Program Review, the controller advances directly to the **Strt** prompt. The Review can be used to bypass making any changes to the current firing schedule.

Options Menu

During an active firing, the Increase/Option button will activate an options menu and scroll through the available options with each button press. These options allow you to make adjustments to the firing program without stopping the firing. The available options follow.

Skip Step

During an active heating, cooling or hold time, it is possible to skip ahead to the next program step. Press the Increase/Option button to display the Skip Step prompt **SStP**. Then Press the Program button to display the current ramp or hold segment. Press the Program button again to initiate the Skip and the controller display returns to the normal firing mode. If the Decrease/Review button is pressed, the Skip function is canceled and the controller display returns to the normal firing mode.

The Skip function can be used to end a Hold time early or to skip from any heating/cooling step to the next heating/cooling step. The Skip function does nothing during the final program step. To end a final program step, simply press Stop.

Add Hold Time

During an active heating, cooling or hold time, it is possible to add more Hold time to the current program step. Press the Increase/Option button until the Hold Time prompt **HLdt** is displayed. Then Press the Program button to display the current hold time. Press the Increase/Option button to add 5 minute increments to the original Hold time. Then press the Program button to return to the normal firing mode. If the Decrease/Review button is pressed while the **HLdt** prompt is displayed, the controller display returns to the normal firing mode.

Change Heating/Cooling Temperature

During an active heating, cooling or hold time, it is possible to change the heating or cooling temperature of the current program step. Press the Increase/Option button until the Change Temperature prompt **CHGt** is displayed. Then press the Program button to display the current temperature setting. Adjust the temperature setting with the Increase or Decrease buttons. Then press the Program button to return to the normal firing mode. If the Decrease/Review button is pressed while the **CHGt** prompt is displayed, the controller display returns to the normal firing mode.

Threshold Alarm

During The firing, it is possible to set an audible alarm and display alarm for when the actual temperature reaches a specified value. The buzzer will sound and the display will show the alarm code **ALAr**.

To set the alarm, Press Increase/Option button during the active firing until the alarm prompt **ALAr** is displayed. Then Press the Program button to display the current alarm temperature setting. Adjust the temperature setting with the Increase or Decrease buttons. Then press the Program button to return to the normal firing mode. If the Decrease/Review button is pressed while the **ALAr** prompt is displayed, the controller display returns to the normal firing mode.

The alarm is disabled (turned off) when the alarm value is set to 32°F (0°C). The alarm value can be reset or changed many times during a single firing. To silence an active alarm, simply press any button. The maximum programmable value for the alarm is 2400°F (1316°C). If the controller does not allow you to program alarm temperatures up to 2400 °F/1316°C, it has been factory set by the supplier to a lower safety temperature. This is often necessary to limit the controller to the maximum operating temperature of the kiln.

Flow Diagram for Options Menu

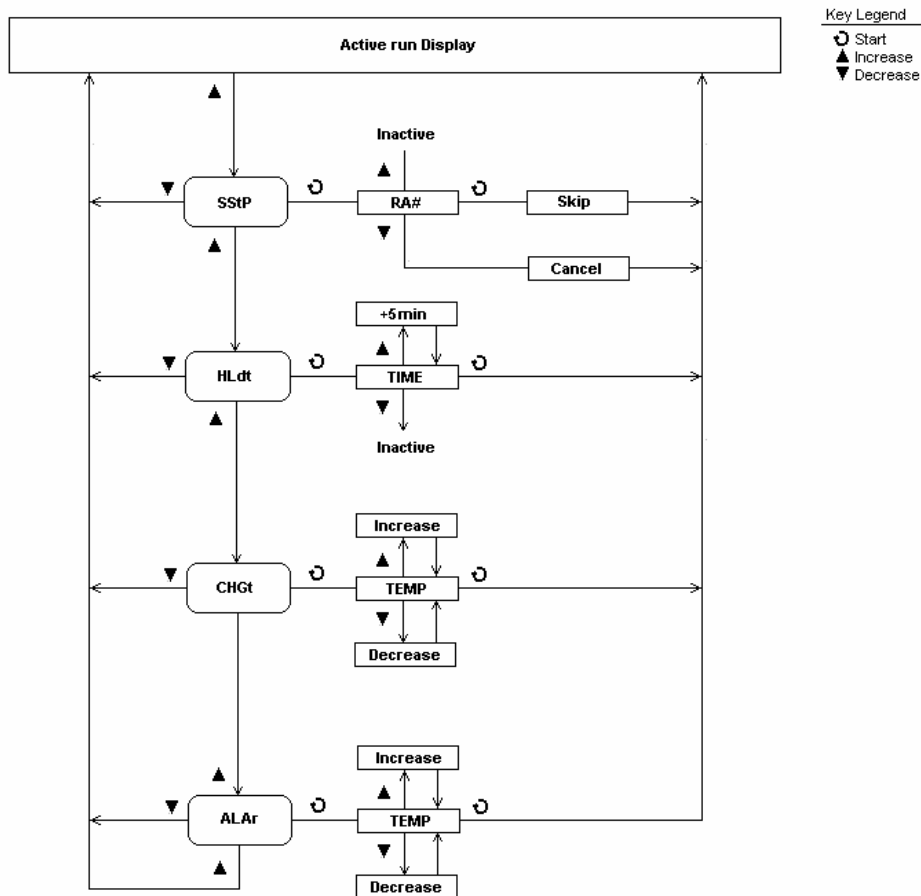

Power Fail Recovery

A firing will resume after a power interruption if certain conditions are met.

1. The controller was not performing a cooling step and the cooling temperature was not exceeded. If so, the display will show the alarm code **PF 1** and terminate the firing.
2. When power is restored the actual temperature must be above 212°F (100°C). If not, the display will show the alarm code **PF 2** and terminate the firing.
3. When power is restored, the temperature drop during the power interruption must be less than 72°F (40°C). If not, the display will show the alarm code **PF 3** and terminate the firing.

Status Display Codes

Below is a list of normal display codes which indicate the controller mode of operation.

- A-4** - This is a short (5 second) display of the Model number which appears every time the controller is turned on.
- IdLE** - This is ready mode; No firing in process. This message will alternate with the temperature display and/or any alarm messages that may occur.
- dELA** - This is the delay start mode. This message will alternate with the delay time count-down if programmed.
- Strt** - This is a final prompt before starting a new firing. The Delay start and Thermocouple Offset features are accessed from this prompt.
- On-** - This is a short (5 second) display that indicates a new firing has been started.
- StOP** - This is an Abort message; the firing was stopped early. This message will alternate with the temperature display and/or any alarm messages that may occur.
- CPLt** - This is a firing complete message; the firing ended successfully. This message will alternate with the temperature display and the total firing time from start to finish.

Alarm Display Codes

In addition to Power failure alarms, these messages may be displayed if the controller detects a problem during the firing.

- tC** - This alarm indicates that the thermocouple sensor is no longer detected. The controller can not operate without a thermocouple signal. In most cases, the thermocouple has failed and will need replacement, or the electrical connections for the thermocouple may be loose or damaged. Check the wiring for the thermocouple and the physical condition of the probe inside the firing chamber.
- tCr** - This alarm indicates that the thermocouple sensor is detected but the signal is reversed. The firing was terminated. The thermocouple signal is a low voltage direct current with +/- polarity. The controller will sense that the temperature is traveling backwards from what is expected. In most cases, the thermocouple needs reconnected properly. Check the wiring for the thermocouple.
- FAIL** - This alarm indicates that the thermocouple sensor is no longer detected. The signal was lost during and active firing and the firing was terminated. The controller can not operate without a thermocouple signal. In most cases, the thermocouple has failed and will need replacement, or the electrical connections for the thermocouple may be loose or damaged. Check the wiring for the thermocouple and the physical condition of the probe inside the firing chamber.
- FTL** - This alarm indicates that the firing was taking too much time to complete and the firing was terminated. The controller monitors the deviation from the desired firing schedule as compared with the actual firing results. There are 2 conditions for the **FTL** alarm.
1. The heating or cooling rate has slowed to less than 27°F (15°C) per Hour
 2. The current program step has lasted 2 hours longer than anticipated.

In most cases, the **FTL** alarm occurs during heating if the heating rate is set to a fast speed that cannot be maintained by the system. If the heating rate is within the systems capability, a component failure has probably occurred with the heating elements or the control relays.

During cool-down, a well insulated system will have cooling limitation and rapid cooling rates may set off this alarm if the cooling speed cannot be maintained. Increasing the final cool-down temperature or slowing the cooling rate can avoid this alarm.

- tCL** - This alarm indicates that the thermocouple signal is not responding to the demand for more system power during heat-up. There are 2 conditions for the **tCL** alarm.
1. The heating or cooling rate has slowed to less than 9°F (5°C) per Hour
 2. The actual kiln temperature is lagging behind the desired temperature by more than 100°F (56°C).

In all cases, the **tCL** alarm occurs during heating when little temperature rise is detected. This can be the result of a component failure at elevated temperatures; most likely a failed heating elements or a control relay. Another possible problem is with the thermocouple sensor signal; if the thermocouple probe is not properly positioned in the firing chamber or if the wiring from the sensor has short-circuited the controller will not detect actual temperature changes in the firing chamber.

EtH - This alarm indicates that the Electronics temperature is too hot for controller operation. The controller temperature must be below 176°F (80°C) to prevent damage to the sensitive electronic. The ETH alarm cannot be cleared unless the board temperature has cooled. If the ETH occurs frequently, check the kiln for heat loss near the controller. Proper venting and heat-shielding should be inspected.

FE # - Fatal software Errors, FE Alarms indicate a hardware failure or software problem with the controller. These alarms will disable the normal controller operation and require corrective action. If a Fatal Error occurs during an active firing, the firing is terminated. These alarms include;

- FE 1 – Failed to read or write to memory device
- FE 2 – Failed memory test during power on
- FE 3 – Corrupt data found in memory
- FE 4 – Errors detecting thermocouple input signal *
- FE 5 – Software Execution failed

Turn the controller off and back on to try and clear the alarm. If the alarm reoccurs immediately or frequently, the controller may require service or replacement.

* FE 4 alarms can often be solved by correcting problems with the system thermocouple. Loose connections or faulty thermocouple wiring or a faulty thermocouple can result in this alarm.

Firing Schedules/Programs

You can store/save up to 6 separate firing programs in the controller memory. Each program can be up to 8 Steps long. During programming the display prompts for the individual firing schedules are **PrO** followed by the program number like **PrO1**, **PrO2**, **PrO3**, etc...

If your controller does not allow for 6 programs, it has been factory set by the supplier for a limiting number of programs. This is often necessary for special applications.

To select any of the available programs, first press the Program button when the display shows IdLE. The last used program will be the first choice on the controller display. If a different program is desired, press the Increase button to select another program. Then press the Program button again when the displays shows the program code you want.

Glass Fusing Programming Example

Below is a typical 4 segment firing schedule for Glass Slumping or Fusing Small 12" square or round and 1/4" or less in thickness.

- Step 1. Heat from room temperature at 300°F/Hour) to 1000°F, with no Hold time.
- Step 2. Then heat at 400°F/Hour to 1480°F, with a hold for 20 minutes
- Step 3. Cool as fast as possible, Full (located below 1°F/Hour), to 1050°F, with no Hold time at 1050°F

- Step 4. Cool from 1050°F to 950°F at 150°F/Hour, and Hold at 950°F for 30 minutes.

- Step 5. Shut-off

To program this schedule from **IdLE** mode;

- 1. Press (Program) button. The controller will display the last active program that was used. **PrO1 – PrO6**
- 2. Press (Program) button again if you want to use the same program that is shown or press (Increase) button to change to another program and then press (Program) button again.
- 3. Program the steps below and press (Program) button after each segment.

rA1 = 0300	°F 1 = 1000	HLd1 = 00.00
rA2 = 0400	°F 2 = 1480	HLd2 = 00.20
rA3 = FULL	°F 3 = 1050	HLd3 = 00.00
rA4 = 0150	°F 4 = 0950	HLd4 = 00.30
rA5 = 0000		

- 4. The display shows **Strt** after the final entry above.
- 5. Press (Program) button one last time to start the firing. Display will show **-On-**

Note: The AF3P controller has 3 options that are very helpful at the high end of the firing.

Skip Step: If the glass has the desired effect before you reach the fuse temperature or before the hold is up, use the skip step to advance to the next segment, which is usually the rapid cool down to the annealing range.

Add Temperature: Temperature can be added in five degree increments if more heat is needed to to obtain the desired affect.

Add Time: Time can be added to a hold during the firing in five minute increments, if the glass needs more time to soak.

NEVER LEAVE A FIRING KILN UNATTENDED!!!!

LET KILN COMPLETE THE FIRING AND THEN SWITCH THE KILN OFF AND LET IT COOL. THE SWITCH CAN BE TURNED ON LATER TO CHECK THE TEMPERATURE INSIDE THE KILN BEFORE OPENING IT (It will show IDLE and the current temperature). THE USER MUST BE THERE AT THE HIGH TEMPERATURE TO ACHIEVE THE DESIRED EFFECT, IT MAY BE NECESSARY TO SKIP STEP OR TO ADD TIME OR TEMPERATURE.

Glass Tack Fusing Programming Example

Below is a typical 4 segment firing schedule for Glass Slumping or Fusing Small 12" square or round and 1/4" or less in thickness.

- Step 1. Heat from room temperature at 300°F/Hour) to 1000°F, with no Hold time.
- Step 2. Then heat at 400°F/Hour to 1350°F, with a hold for 10 minutes
- Step 3. Cool as fast as possible, Full (located below 1°F/Hour), to 1050°F, with no Hold time at 1050°F

- Step 4. Cool from 1050°F to 950°F at 150°F/Hour, and Hold at 950°F for 30 minutes.

- Step 5. Shut-off

To program this schedule from **IdLE** mode;

Press (Program) button. The controller will display the last active program that was used. **PrO1 – PrO6**

Press (Program) button again if you want to use the same program that is shown or press (Increase) button to change to another program and then press (Program) button again.

Program the steps below and press (Program) button after each segment.

rA1 = 0300	°F 1 = 1000	HLd1 = 00.00
rA2 = 0400	°F 2 = 1350	HLd2 = 00.10
rA3 = FULL	°F 3 = 1050	HLd3 = 00.00
rA4 = 0150	°F 4 = 0950	HLd4 = 00.30
rA5 = 0000		

The display shows **Strt** after the final entry above.

Press (Program) button one last time to start the firing. Display will show **-On-**

Note: The AF3P controller has 3 options that are very helpful at the high end of the firing.

Skip Step: If the glass has the desired effect before you reach the tack fuse temperature or before the hold is up, use the skip step to advance to the next segment, which is usually the rapid cool down to the annealing range.

Add Temperature: Temperature can be added in five degree increments if more heat is needed to obtain the desired effect.

Add Time: Time can be added to a hold during the firing in five minute increments, if the glass needs more time to soak.

NEVER LEAVE A FIRING KILN UNATTENDED!!!!

LET KILN COMPLETE THE FIRING AND THEN SWITCH THE KILN OFF AND LET IT COOL. THE SWITCH CAN BE TURNED ON LATER TO CHECK THE TEMPERATURE INSIDE THE KILN BEFORE OPENING IT (It will show IDLE and the current temperature). THE USER MUST BE THERE AT THE HIGH TEMPERATURE TO ACHIEVE THE DESIRED EFFECT, IT MAY BE NECESSARY TO SKIP STEP OR TO ADD TIME OR TEMPERATURE.

Glass Slumping Programming Example

Below is a typical 4 segment firing schedule for Glass Slumping or Fusing Small 12" square or round and 1/4" or less in thickness.

- Step 1. Heat from room temperature at 300°F/Hour) to 1000°F, with no Hold time.
- Step 2. Then heat at 400°F/Hour to 1220°F, with a hold for 5 minutes
- Step 3. Cool as fast as possible, Full (located below 1°F/Hour), to 1050°F, with no Hold time at 1050°F

- Step 4. Cool from 1050°F to 950°F at 150°F/Hour, and Hold at 950°F for 30 minutes.

- Step 5. Shut-off

To program this schedule from **IdLE** mode;

Press (Program) button. The controller will display the last active program that was used. **PrO1 – PrO6**

Press (Program) button again if you want to use the same program that is shown or press (Increase) button to change to another program and then press (Program) button again.

Program the steps below and press (Program) button after each segment.

rA1 = 0300	°F 1 = 1000	HLd1 = 00.00
rA2 = 400	°F 2 = 1220	HLd2 = 00.05
rA3 = FULLL	°F 3 = 1050	HLd3 = 00.00
rA4 = 0150	°F 4 = 0950	HLd4 = 01.00
rA5 = 0000		

The display shows **Strt** after the final entry above.

Press (Program) button one last time to start the firing. Display will show **-On-**

Note: The AF3P controller has 3 options that are very helpful at the high end of the firing.

Skip Step: If the glass has the desired effect before you reach the slump temperature or before the hold is up, use the skip step to advance to the next segment, which is usually the rapid cool down to the annealing range.

Add Temperature: Temperature can be added in five degree increments if more heat is needed to to obtain the desired affect.

Add Time: Time can be added to a hold during the firing in five minute increments, if the glass needs more time to soak.

NEVER LEAVE A FIRING KILN UNATTENDED!!!!

LET KILN COMPLETE THE FIRING AND THEN SWITCH THE KILN OFF AND LET IT COOL. THE SWITCH CAN BE TURNED ON LATER TO CHECK THE TEMPERATURE INSIDE THE KILN BEFORE OPENING IT (It will show IDLE and the current temperature). THE USER MUST BE THERE AT THE HIGH TEMPERATURE TO ACHIEVE THE DESIRED EFFECT, IT MAY BE NECESSARY TO SKIP STEP OR TO ADD TIME OR TEMPERATURE.

Annealing Schedule for Spherical Moretti/Murano Glass “Turn On, Ramp Up and Work Program”

Annealing temperature range for Moretti or Murano Glass: 940-970 degrees Fahrenheit
General Rule of thumb: 30 minutes to one hour of soak time for each .5 (half) inch diameter of Moretti or Murano

Below is the computer language for the Jen-Ken Kiln with an AF3P Controller and a Flip Door

Turn on the kiln from IDLE press program button and select USER1 using the up Arrow key, then press the Program button. The down arrow button at this point is the program review button or press the program button again to add or change the program. This program will be entered in **USER1** and have 3 segments. **Ra1** means the first Rate per hour (FULL is located using the down arrow to 0 and press again to FULL), **oF1** means the first temperature to go to, and **Hd1** means the first Hold time in hours and minutes.

User 1	Ra1	Full- deg./hr	Full Power
	oF1	940 degrees	940 degrees F
	Hd 1	6 Hours	(Enter Longest Time Working)
	Ra 2	Full- deg./hr	Full Power
	oF2	940 degrees	
	Hd 2	30 min	30 minute Soak Prior to Ramp Down for half inch dia. beads
	Ra 3	600 deg./hr	Ramps down to 400 deg. The kiln cools down slowly to room temperature
	oF3	400 degrees	
	Hd 3	0 min	

Press Program Key Twice to Start

The program is now complete.

Note: At the end of the lampworking session if it is less than the 6 hour hold in Hold 1; one needs to use the “Skip Step” function to skip out of Hold 1 and into Hold 2. This will allow the last bead made to get 30 minutes of soak before the kiln ramps down.

Important: Do not leave a firing kiln unattended.

Batch Annealing Program: From a “Cold Start”

General “Rule of Thumb” as to the annealing of the soft Soda-Lime glass known at the Moretti or Murano Glass: 30 minutes to 1 hour of soak time for each .1/2 inch diameter of Moretti or Murano glass.

Below is the computer language for the Jen-Ken Kiln with a AF3P Controller and a Flip Door

Turn on the kiln from IDLE press program button and select USER2 using the up Arrow key, then press the Program button. The down arrow button at this point is the program review button or press the program button again to add or change the program. **User 2:** This program will be entered in **USER2** and have 2 segments. **Ra1** means the first Rate per hour (FULL is located using the down arrow to 0 and press again to FULL), **oF1** means the first temperature to go to, and **Hd1** means the first Hold time in hours and minutes.

User 2	Ra1	850 deg./hr	(14.16 degrees F per minute)
	Temp1	940 degrees	940 degrees F
	Hold 1	1 Hour	(Enter Appropriate Time for Diameter)
	Ra 2	600 deg./hr	
	Temp 2	400 degrees	Ramps down to 400 degrees. The kiln cools down slowly to room temperature
	Hold 2	0 min	
	Press Program Key Twice to Start		

The program is now complete.

Note: The kiln will heat soak the bead for one hour then come down. The one hour hold can be changed for larger diameter beads.

Important: Do not leave a firing kiln unattended.

Basic Borosilicate Annealing Program

Below is the computer language for the Jen-Ken Kiln with a AF3P Controller and a Flip Door

Turn on the kiln, the display will show IDLE and the temperature, press the program button and select USER3 using the up Arrow key, then press the Program button. The down arrow button at this point is the program review button or press the program button again to program. **User 3:** This program will be entered in **USER3** and have 3 segments. **Ra1** means the first Rate per hour (FULL is located using the down arrow to 0 and press again to FULL), **oF1** means the first temperature to go to, and **Hd1** means the first Hold time in hours and minutes.

User 3	Ra1	FULL - deg./hr	Full Power Ramp Up
	Temp1	1050 degrees	The annealing temp range for Borosilicate glass is between 1050 and 1125 degrees F
	Hold 1	6 Hours	
	(Enter Longest Time Working)		
	Ra 2	FULL - deg./hr	Full Power
	Temp	940 degrees	
	Hold 2	30 min	30 minute Soak Prior to Ramp Down for half inch dia. beads
	Ra 3	600 deg./hr	
	Temp 3	400 degrees	Ramps down to 400 degrees. The kiln cools down slowly to room temperature
	Hold 3	0 min	

Press Program Key Twice to Start.

The program is now complete.

Keep in mind that annealing Borosilicate Colors that “strike”...in which most of them do...these striking colors work on the process of nuclei formation. This gives rise to the size and number of crystals formed that in turn produces the resultant color that strikes out. So, for the Ruby family... you might want to anneal them early one in your annealing session, not keeping them in too long.. For over annealing the Boro-Ruby family causes them to over-strike and become livery in appearance. The cadmium based opaque colors are not bound by this law.. for they do not strike, yet one does not want to get them too hot, or be too “harsh on them” when working with them in one’s flame chemistry. So flame chemistry and annealing strike time are the secrets to proper color achievement in Borosilicate Glass. Have Fun! Keep Record Logs of Your Color Annealing Times, and the Flame Chemistry’s that you use in order to master the Boro Color palette. Record the “timing of your work”, and every nuance of it, in the flame chemistries used, annealing times, etc.

Note: At the end of the lampworking session if it is less than the 6 hour hold in Hold 1; one needs to use the “Skip Step” function to skip out of Hold 1 and into Hold 2. This will allow the last bead made to get 30 minutes of soak before the kiln ramps down.

Important: Do not leave a firing kiln unattended.

Orton Controller Limited Warranty

This limited warranty is given only to the immediate purchaser ("Buyer") of the Autofire®Express kiln controller. This limited warranty is not transferable. The Edward Orton Jr. Ceramic Foundation ("Orton") warrants the controller motherboard installed on the Autofire®Express ("Warranted Components") to be in good working order under normal operating conditions for a period of one (1) year from the date of purchase. Should the Warranted Components fail to be in good working order at any time during the stated one (1) year period, Orton will, at its option, repair or replace the Warranted Components as set forth below. The liability of Orton is limited to replacement and/or repair at its factory of the Warranted Components that does not remain in good working order. Repair parts or replacement products will be furnished on an exchange basis and will be either reconditioned or new. All replaced parts or products become the property of Orton. Following receipt of notice from Buyer of a valid warranty claim and the Autofire®Express containing the Warranted Components, Orton will perform its obligations under this limited warranty within 10 business days.

Limited warranty service may be obtained by delivering the Autofire®Express during the warranty period to your Orton Supplier or to The Edward Orton Jr. Ceramic Foundation, 6991 Old 3C Highway, Westerville, Ohio 43082 and providing written proof of purchase and a description of the defect or problem. Buyer must insure the shipment or assume the risk of loss or damage in transit, prepay shipping charges to the service location, and use the original shipping container or equivalent. Buyer will be responsible for shipping and handling charges in excess of US \$50.00 incurred by Orton in returning the Autofire®Express to the Buyer after completion of limited warranty service.

This warranty does not apply to any damage to the Autofire®Express resulting from:

- Operation beyond electrical rating.
- External sources including, but not limited to, chemicals, heat abuse and improper care.
- Improper or inadequate maintenance by Buyer.
- Parts or equipment not supplied by Orton.
- Unauthorized modification or misuse.
- Operation outside environmental specifications.
- Improper installation.
- Over firing (melting of materials being fired) regardless of the cause of the over firing.

Warranted Components returned for service where no warranted defect is found will be subject to service, and shipping and handling fees.

If the Warranted Components are not in good working order as warranted above, Buyer's sole remedy shall be repair or replacement of the Warranted Components as provided above.

TO THE EXTENT PERMITTED BY LAW, ALL EXPRESS AND IMPLIED WARRANTIES FOR THE WARRANTED COMPONENTS INCLUDING THE WARRANTIES OF MERCHANTABILITY AND FITNESS FOR A PARTICULAR PURPOSE ARE LIMITED TO THE ONE YEAR WARRANTY PERIOD COMMENCING ON THE DATE OF PURCHASE, AND NO OTHER WARRANTY WHETHER EXPRESS OR IMPLIED WILL APPLY TO THIS PERIOD. TO THE EXTENT PERMITTED BY LAW, ORTON'S REMEDY AND BUYER'S SOLE REMEDY IS LIMITED SOLELY AND EXCLUSIVELY TO REPAIR OR REPLACEMENT AS SET FORTH HEREIN. ORTON SHALL NOT BE LIABLE FOR, AND BUYER'S REMEDY SHALL NOT INCLUDE ANY INCIDENTAL, CONSEQUENTIAL OR OTHER DAMAGES OF ANY KIND WHATSOEVER, WHETHER A CLAIM IS BASED UPON THEORY OF CONTRACT, NEGLIGENCE OR TORT.

Buyer shall determine suitability of the Autofire®Express for the intended use and assume all risk and liability therewith. Some states do not allow this exclusion or limitation of incidental or consequential damages, so the above limitation or exclusion may not apply to you. This warranty gives you specific legal rights, and you may also have other rights which vary from State to State.

The above limitation does not apply in the event that any Warranted Components are determined by a court of competent jurisdiction to be defective and to have directly caused bodily injury, death or property damage; provided that in no event shall Orton's liability exceed the greater of \$1,000.00 or the purchase price of the specific Autofire®Express that caused such damage.

Service may also be obtained on Warranted Components no longer under warranty by returning the Autofire®Express prepaid to Orton with a description of the problem and Buyer's name and contact information. Buyer will be contacted with an estimate of services charges before any work is performed.

Customer Satisfaction Policy

If for any reason you are not completely satisfied with the performance of the Orton Autofire®Express or the conditions of this warranty, return the Autofire®Express in good working condition, transportation and insurance prepaid, within 30 days of purchase date to your supplier or The Edward Orton Jr. Ceramic Foundation, 6991 Old 3C Highway, Westerville, Ohio 43082 and your purchase price will be refunded. Prior to returning your Autofire®Express contact Orton for an authorization number and include with your shipment. For controllers ordered in error, a restocking charge will apply.

History of Orton

Helping the Ceramic Community grow since 1896

In 1896, Professor Edward Orton Jr. began the Standard Pyrometric Cone Company, manufacturing Pyrometric cones at Ohio State University. These cones quickly became the standard by which firings were monitored and controlled, as they often are today.

Because of his interest and commitment to advancing the ceramic arts and industries and his desire to have high quality Pyrometric cones always available for monitoring and control of the firing process, Orton left his company as a nonprofit Trust. Income is used to develop and disseminate technical information that helps solve firing and other processing problems.

Orton's Center for Firing provides information and technical assistance on customer-specific firing problems, as well as publications, technical notes and other related information.

The Orton product line includes a full range of Kiln Monitoring Products, Temperature Controls, Venting Systems, Testing Services and Laboratory Instruments.

Visit us on the web at WWW.ORTONCERAMIC.COM

Thank You for Purchasing Orton Products and contributing to the advancement of Ceramic Arts.

Available with optional Firing Programs;

Ceramic Cone-fire with 4 Ramp/Hold Programs

Jewelry Burn-out with 4 Ramp Hold Programs

PMC with 1 Ramp/Hold Program

Speed Settings with 4 Ramp/Hold Programs

No Preset Programs with 6 Ramp/Hold Programs

**Orton Ceramic Foundation - 6991 Old 3C Highway, Westerville, OH 43082-9026
Phone (614) 895-2663, Fax (614) 895-5610
(www.ortonceramic.com)**

Flow Diagram for Program Selection

